



ABOVE AND BEYOND HONING

HTA SERIES

HORIZONTAL TUBE HONING SYSTEMS



SUNNEN'S NEW HTA TUBE HONES PACK HIGH-END FE



Before now, to get horizontal tube honing capabilities, you had to invest in large systems that tied up valuable floor space – not to mention valuable capital. But with our new HTA tube hone, Sunnen® introduces the first all-electric, lean design tube hone created specifically for hydraulic service facilities doing resurfacing and repair of actuators for construction, mining, farming, and forestry equipment. It is also ideally suited for other applications such as flow tube/meter run cleanup, extruder tube repair and other low stock removal applications.

The HTA is available in two models: the HTA-2000 [featuring a 2-meter (6.56 ft) stroke], and the HTA-4000 [featuring a 4-meter (13.12 ft) stroke]. These systems are designed for bore diameters from 2.5 – 21 inches (64 – 533 mm), and part weights to 4,000 pounds (1815 kg).

ATURES INTO AN AFFORDABLE, FLEXIBLE SYSTEM



The HTA tube hone is ideal for resurfacing and repair work where light-duty stock removal up to 0.030 inches (0,76 mm) is needed to oversize deeply scored actuator bores. The spindle, powered by a 3 Hp (2,24 kW) AC gear motor, is controlled over a 20-300 rpm speed range. The servo stroking system has a speed range of 5 – 90 ft/min (1,52 – 27,4 m/min).

This affordable and versatile system boasts many features found on high-end machines, such as a PLC-control with touch-screen interface for setting all machine parameters, including stroke reversal, spindle/stroking speeds, and crosshatch angle calculation. The control features a load meter to determine areas of bore tightness, with the ability to dwell and short-stroke the tool in multiple areas to correct part geometry. Other advanced capabilities include choice of manual or automatic tool tensioning, set through the PLC.

Your Sunnen Technical Specialist will work with you to determine the best solution for your needs – it's all part of the added value you get with Sunnen. Plus, our worldwide sales and service team provides comprehensive support for the installation and operation of every system we make.

Whatever your need, we have the expertise and product range to create the right solution for you and the dedication to support you for the long run.

SUNNEN AND THE SUNNEN LOGO ARE REGISTERED TRADEMARKS OF SUNNEN PRODUCTS COMPANY



HIGH-END FEATURES GIVE THE HTA TUBE HONING SYSTEM GREAT VERSATILITY AND VALUE



ELECTROMECHANICAL STROKER AND SPINDLE, features a Siemens servo stroker motor with belt drive for quiet and precise operation combined with a 3 Hp (2,24 kW) spindle unit.

AUTO TENSIONING SYSTEM includes a programmable auto tool feed that's standard equipment on the HTA. However, the abrasives can also be fed up manually, if desired.

PAPER MEDIA COOLANT FILTRATION UNIT has a 48 gallon (182 l) capacity, and comes standard with quick disconnects, casters for mobility, sight glass, and a manual paper bed filter to clean the oil. The unit is powered by a reliable, robust 15 gpm (55 lpm) centrifugal pump, is designed to be easy to maintain, and tucks neatly under the HTA's frame.

STANDARD, NON-CE GUARDING includes easily removable covers for each end of the honed part for safety and coolant splash retention. Optional CE guarding is available.

THE INNOVATIVE MODULAR WORKPIECE SUPPORT handles up to 4,000 lbs (1815 kg).

POWERFUL SIEMENS PLC WITH COLOR TOUCH SCREEN controls the electrical functions of the system in conjunction with standard push buttons and a joystick. Dwelling in any part of the stroke is handled via the touch screen.

THE STROKER JOYSTICK on the control panel allows the operator to move the honing tool over the entire stroke length to set the ends of the stroke during setup. The stroke control override allows short-stroking in any part of the bore to allow the clean-up of any tight spots.

THE OPERATOR STATION swivels for ease of setup and operation.

MULTIPLE LANGUAGES (English, Spanish, German, French Italian) selectable from touch screen. Metric/inch conversion also selectable from touch screen.

ANALOG-STYLE LOAD METER allows quick location of bore tight spots.

STANDARD UNIVERSAL V-BLOCK WORK HOLDING SYSTEM provides flexible, quick fixturing of a variety of work pieces.

HTA FLOOR PLAN LAYOUT AND DIMENSIONS

This versatile system packs a lot of performance into an efficient footprint that's significantly smaller than other horizontal tube honing systems.

HTA-2000

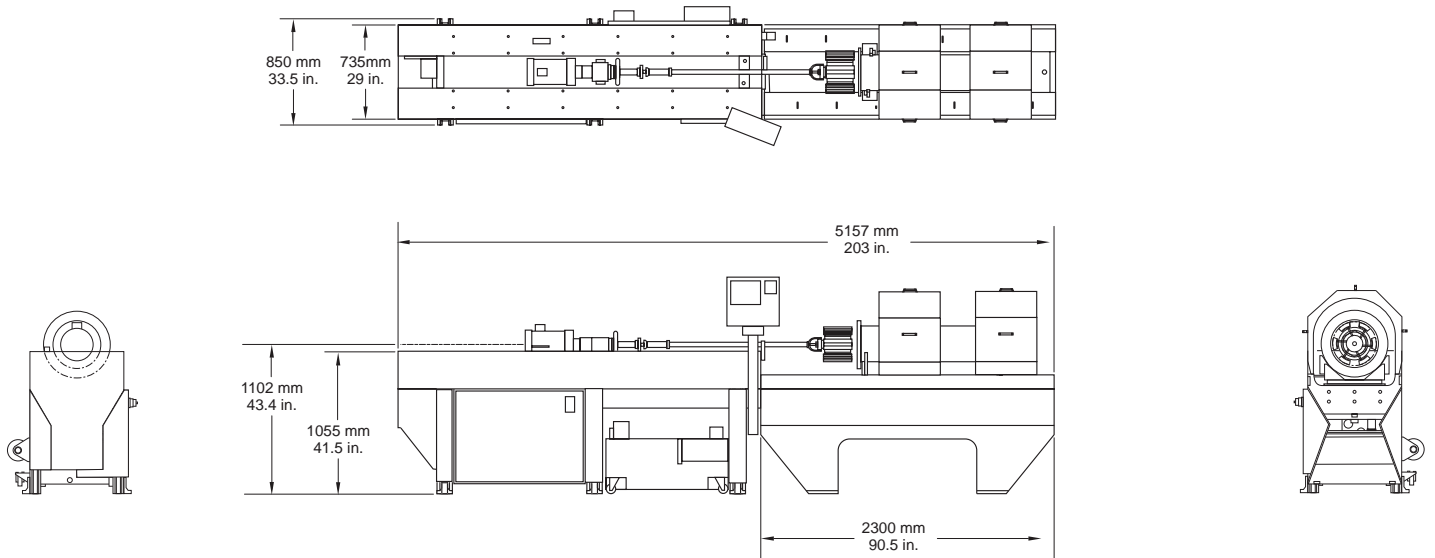

HTA-4000

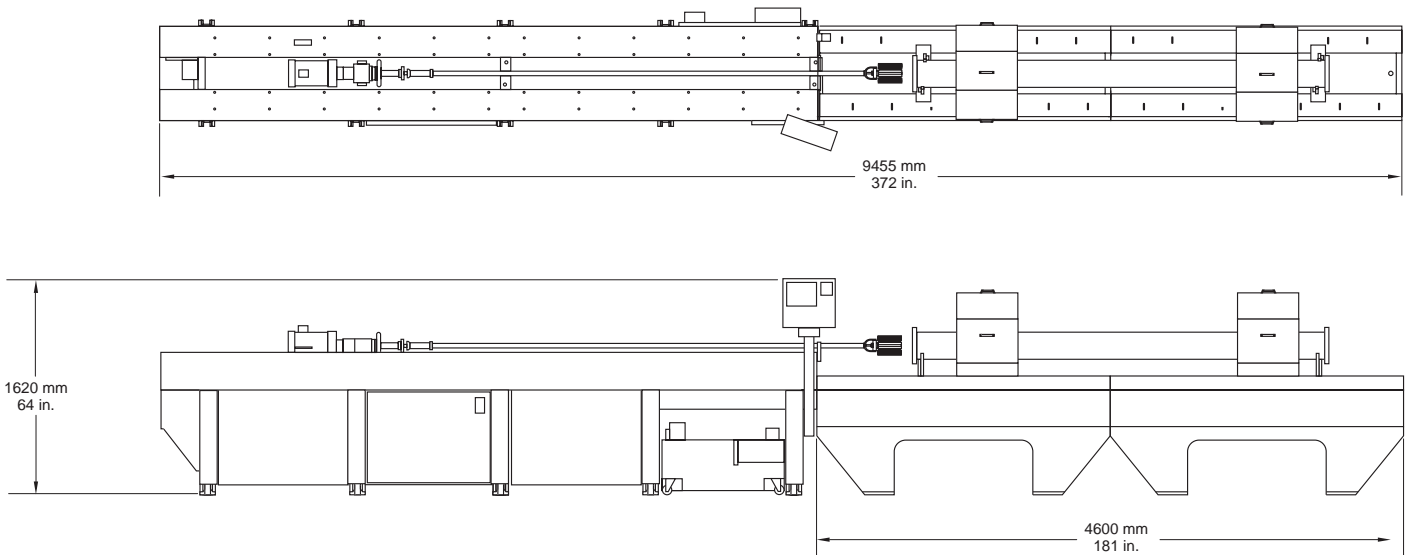

THE HTA IN ACTION

Sunnen's new HTA tube hone is suited for a wide range of applications, including reconditioning of hydraulic cylinders, die casting shot tubes, plastics extruder barrels and gas flow meter tubes.



The HTA is an all-electric machine. And no hydraulics mean less noise, no leaks, better control, and more accuracy during bore reversals.



A flexible, modular work-holding system allows rapid setups of a wide variety of workpieces.



All machine features are controlled via the PLC controlled operator station, meaning no hydraulic valves to adjust or limit switches to move. The operator station swivels for ease of use. Color monitor is standard.

SPECIFICATIONS:

SPINDLE SPEED:

20 – 300 RPM

SPINDLE POWER:

3 Hp (2,24 kW)

STROKE:

1.5 Hp (1,12 kW)

STROKE SPEED RANGE:

5 – 90 ft/min (1,52 – 2,74 m/min)

BORE DIAMETER RANGE:

2.5 – 21 inches (64 – 533 mm)*

*FOR DIAMETER SIZES BELOW 2.5 INCHES (64MM), CONTACT YOUR SUNNEN FIELD ENGINEER.

APPROXIMATE STOCK REMOVAL RATE:

8in³/hr (130 cm³/hour)*

*STEEL MATERIAL WITH CONVENTIONAL ABRASIVES. ACTUAL STOCK REMOVAL RATES WILL VARY DEPENDING UPON APPLICATION.

MAXIMUM PART WEIGHT:

HTA-2000 – 4,000 lbs (1815 kg)

HTA-4000 – 4,000 lbs (1815 kg)

APPROXIMATE WEIGHT (INCLUDES COOLANT CART):

HTA-2000 – 2,400 lbs (1088 kg)

HTA-4000 – 4,000 lbs (1815 kg)

ELECTRICAL SYSTEM:

400/460 V, 50/60 Hz, 3 phase, 15 amp

Designed in accordance with NEC/NFPA 79

Optional transformer configurations also available

ORDERING INFORMATION:

The HTA is available in two configurations:

- HTA-2000 [featuring a 2-meter (6.56 ft) stroke]
- HTA-4000 [featuring a 4-meter (13.12 ft) stroke]

OPTIONAL EQUIPMENT:

- Additional work holding configurations
- CE guarding
- Transformer configurations to accommodate voltage/frequency combinations beyond 400 VAC 50 Hz / 460 VAC 60 Hz

HTA SERIES TOOLING, ABRASIVES, HONING OILS AND COOLANTS

TOOLING

The HTA is compatible with Sunnen portable tooling for precise, accurate and consistent bore sizing. It is specifically designed around the ANR-275 style tooling system with the ANR-160 hone head. Those shops already using ANR-style tooling can also use it with the HTA tube hone, including stone supports, master holders and abrasives.

BORE DIAMETER RANGE:
2.5 – 21 inches (64 – 533 mm)*

**FOR DIAMETER SIZES BELOW 2.5 INCHES (64MM), CONTACT YOUR SUNNEN FIELD ENGINEER.*



ANR-160A-style Portable Hone assembled with Stone Support, Single Length Master Holder Set, Stone Set and Drive Shank.

SUNNEN-MADE ABRASIVES

From aluminum oxide to silicon carbide to diamond and CBN, Sunnen manufactures the industry's largest variety of mounted or un-mounted stick abrasives, bond types, grain sizes and stone configurations.

Before any stone is shipped, it is graded and qualified, maintaining the most exacting quality control standards in the industry to assure you of the most precise and consistent honing performance available.



SUNNEN PREMIUM HONING OILS & COOLANTS

Sunnen's premium honing oils and coolants provide extreme lubricity for higher honing pressure and harder abrasives, delivering faster, lower cost-per-part and ultimately more profitable cutting rates.





A LEGACY OF EXCELLENCE SINCE 1924.

WORLDWIDE

Our global manufacturing, sales, and service network allows us to deliver quality Sunnen solutions worldwide. And our network of more than 50 authorized Sunnen international distributors is second to none.

Sunnen's state-of-the-art Advanced Technology Centers – located in the US, Switzerland, and China – allow our technical experts to develop innovative solutions to customer application challenges. The Centers also provide answers for customer questions and training for Sunnen representatives around the globe.

SUNNEN PRODUCTS COMPANY

World Headquarters
St. Louis, MO – USA
Phone 1.314.781.2100
Fax 1.314.781.2268
Toll Free 1.800.325.3670
Email sunnen@sunnen.com
www.sunnen.com

SWITZERLAND – SUNNEN AG

Phone +41 71 649 33 33
Fax +41 71 649 33 34
Email info@sunnen.ch
www.sunnen.ch

ITALY – SUNNEN ITALIA S.R.L.

Phone +39 02 383 417 1
Fax +39 02 383 417 50
Email sunnen@sunnenitalia.com
www.sunnenitalia.com

FRANCE – SUNNEN SAS

Phone +33 01 69 30 0000
Fax +33 01 69 30 1111
Email info@sunnen.fr
www.sunnen.fr

UK – SUNNEN PRODUCTS LTD.

Phone +44 1442 39 39 39
Fax +44 1442 39 12 12
Email hemel@sunnen.co.uk
www.sunnen.co.uk

POLAND – SUNNEN POLSKA SP. Z O.O.

Phone +48 22 814 34 29
Fax +48 22 814 34 28
Email sunnen@sunnen.pl
www.sunnen.pl

RUSSIA – SUNNEN RUS

Phone +7 495 258 43 43
Fax +7 495 258 91 75
Email sunnen@sunnen-russia.ru
www.sunnen.ru

CZECH REPUBLIC – SUNNEN S.R.O.

Phone +420 383 376 317
Fax +420 383 376 316
Email sunnen@sunnen.cz
www.sunnen.cz

CHINA – SHANGHAI SUNNEN MECHANICAL CO. LTD.

Phone +86 21 5813 3990
Fax +86 21 5813 2299
Email shsunnen@sunnensh.com
www.sunnensh.com



SUNNEN AND THE SUNNEN LOGO ARE REGISTERED TRADEMARKS OF SUNNEN PRODUCTS COMPANY

Sunnen reserves the right to change or revise specifications and product design in connection with any feature of our products contained herein. Such changes do not entitle the buyer to corresponding changes, improvements, additions, or replacements for equipment, supplies or accessories previously sold. Information contained herein is considered to be accurate based on available information at the time of printing. Should any discrepancy of information arise, Sunnen recommends that user verify the discrepancy with Sunnen before proceeding.