

I-CF-502C

## OPERATING INSTRUCTIONS

SUNNEN CF-502  
SETTING FIXTURE  
DIAMETER RANGE:  
0" - 2.000"



## TABLE OF CONTENTS

	Page
Basic Unit . . . . .	3
Accessories . . . . .	4
Using the CF-502 . . . . .	5
Checking the CF-502 Calibration . . . . .	14

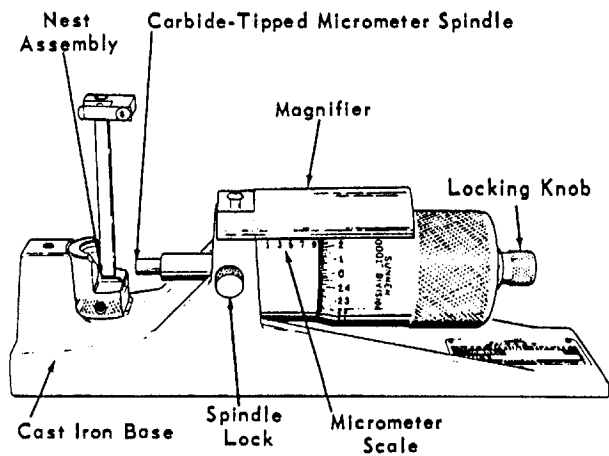

CF-502 SETTING FIXTURE

FIGURE 1

The Sunnen CF-502 Setting Fixture greatly simplifies the precise setting of the Sunnen GA-4000, GR-6000, and GR-9000 Series Dial Bore Gages.

## **BASIC UNIT**

The CF-502 (see Figure 1) includes the following:

- (1) A one-piece, stress-relieved cast-iron base frame;
- (2) Three hardened steel Nest Assemblies for the Sunnen GA-4000, GR-6000, and GR-9000 Series Dial Bore Gages (only one Nest shown);
- (3) A tenth-reading (.0001") Micrometer Head with carbide-tipped spindle;
- (4) A Micrometer Spindle Lock;
- (5) A Magnifier for easier reading of the Micrometer Scale.

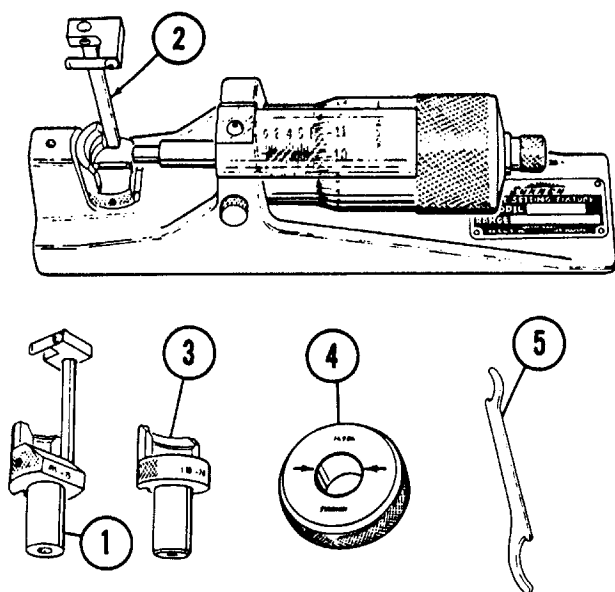

**FIGURE 2**

**CF-502 ACCESSORIES (Figure 2):**

- (1) CF-550A Nest Assembly – for the GA-4000 Series Gage;
- (2) CF-560A Nest Assembly – for the GR-6000 Series Gage;
- (3) CF-570A Nest Assembly – for the GR-9000 Series Gage;
- (4) CF-576A – a .750'' diameter Master Ring;
- (5) CF-137A Spanner Wrench;
- (6) CF-580A Storage Case (not shown);
- (7) PG-991 Anti-Rust Compound (not shown);

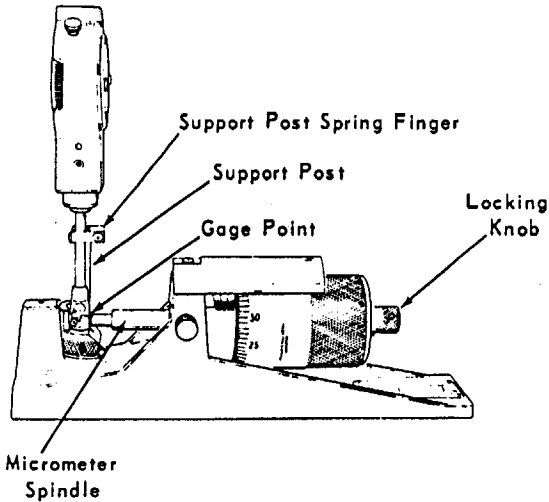

**FIGURE 3**

## USING THE CF-502

These instructions outline the setup of the Sunnen GA-4000, GR-6000, and GR-9000 Series Gages with the CF-502 Setting Fixture. The CF-502 (see Figure 3) may be used without removing it from the storage case. However, if it is removed from the case, do not lift the Fixture by the Micrometer Head.

1. Clean the Micrometer Spindle tip thoroughly.
2. Select the correct Gage and Gage Point for the bore you are measuring. If, for example, you are measuring a .5150" diameter bore, you would use a GA-4000 Series Gage and the smallest of the three Gage Points that come with that Gage (No. 1).

3. Examine the Quick-Setting Wrench. Note that the Lock Nut Drive slot is milled off center, making one lug larger than the other, and that the same is true concerning the Gage Point Drive slot. See Figure 4. Note also that the large lug of the Lock Nut Drive slot is in line with the Micrometer Scale of the Wrench (see Figure 5).

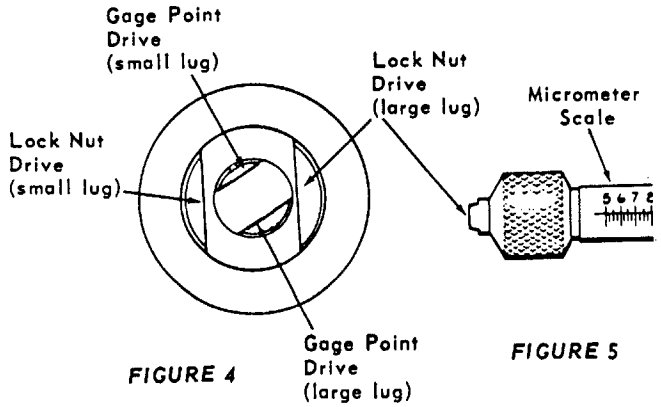

4. Now examine the Gage Point and Lock Nut Assembly. Note that the flats on both the Lock Nut and the end of the Gage Point are milled off center, making one flat larger than the other (see Figure 6).

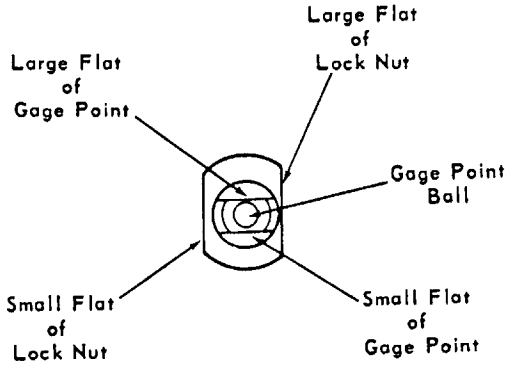

**FIGURE 6**

**IMPORTANT:** Note that one side of the Lock Nut has a large chamfer (see Figure 7). This chamfer must be installed toward the Gage Head.

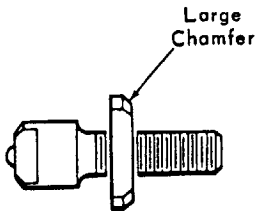

**FIGURE 7**

5. Install the Gage Point in the Dial Bore Gage as follows.
  - a. Slide the Adjusting Knob of the Quick-Setting Wrench all the way out (extreme open position). See Figure 8.

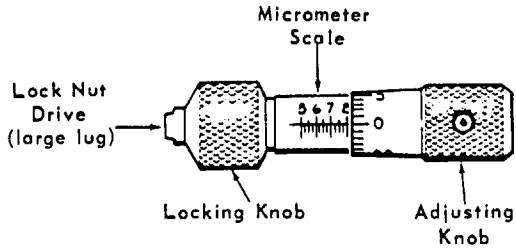

FIGURE 8

- b. Hold the Quick-Setting Wrench so the graduations on the Micrometer Scale are facing up. Insert the Gage Point (with the large flat of the Lock Nut facing up) into the Quick-Setting Wrench.
- c. Slide the Adjusting Knob inward and turn slowly until the Gage Point Drive slot engages the flats on the Gage Point.
- d. Hold the Quick-Setting Wrench at a slight angle, with the Gage Point upward. Screw the Gage Point into the Dial Bore Gage until the Lock Nut contacts the Gage Head. Do not tighten the Lock Nut.
- e. Holding the Lock Nut in this position, turn the Adjusting Knob to the desired setting. Keep a light inward pressure on the Adjusting Knob while setting. Always come to the final setting while turning the Adjusting Knob in a clockwise direction (when viewed from the Adjusting Knob end).

- f. Tighten the Lock Nut by turning the Locking Knob and the Adjusting Knob at the same time, keeping just enough tension on the Adjusting Knob to maintain the micrometer setting.
  
- g. In the final calibration of the Dial Bore Gage (when using the Sunnen CF-502 Setting Fixture or a ring gage), the "0" point of the Indicator Hand may not be in the most desirable reading position. To change the position, place the Quick-Setting Wrench on the Gage Point and observe the micrometer reading. Then loosen the Lock Nut and turn the Adjusting Knob until the micrometer reading changes the amount you would like the Indicator Hand to move.

6. Select the correct Nest (refer to the marking on the Nest or to Table 1 below) and place it in the Setting Fixture. For our example (a .5150'' diameter bore), you would select CF-550A, whose diameter range is .495'' to .750''. Note that each Gage Series will seat properly on only one Nest.

Diameter Range Inches	Gage Series	Nest No.
.495 - .750	GA-4000	CF-550A
.740 - 1.190	GR-6000	CF-560A
1.180 - 2.000	GR-9000	CF-570A

Table 1

7. Be sure the Spindle Lock on the CF-502 is disengaged. Set the Micrometer Head to a point about .025'' greater than the size desired. For our example (.5150), you would set the Micrometer to a point between .5350 and .5450.

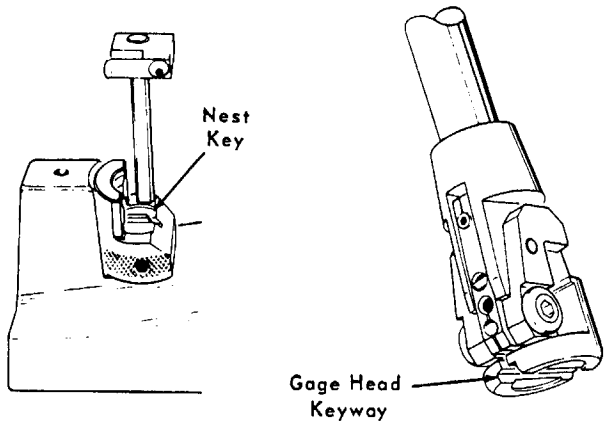
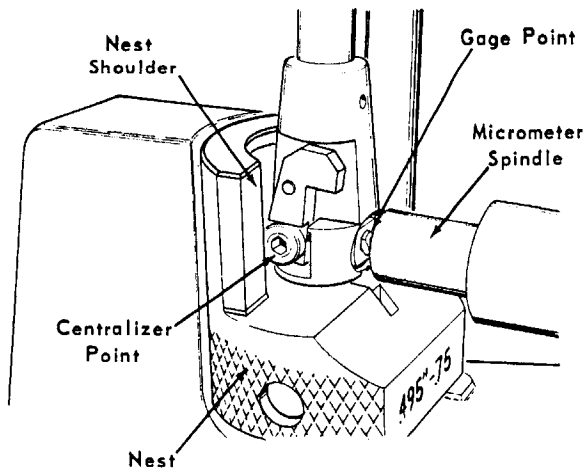

FIGURE 9

8. **CAREFULLY**, place the Gage in the Nest so the Keyway in the Gage Head engages the Key in the Nest (see Figure 9). Be sure the Gage Point is toward the Micrometer Spindle (see Figure 10).



**FIGURE 10**

When using a GA-4000 or GR-6000 Series Gage, the Gage will be held upright by the Support Post and Support Post Spring Finger.

9. Turn the Micrometer Spindle in until it reads the exact size being set (.5150 in our example). Tighten the Spindle Lock. The carbide tip of the Micrometer Spindle should now be in contact with the Gage Point.  
Remember: Always set the Micrometer by moving from big to small. If you overshoot the desired setting, back up the Micrometer Spindle and reset.

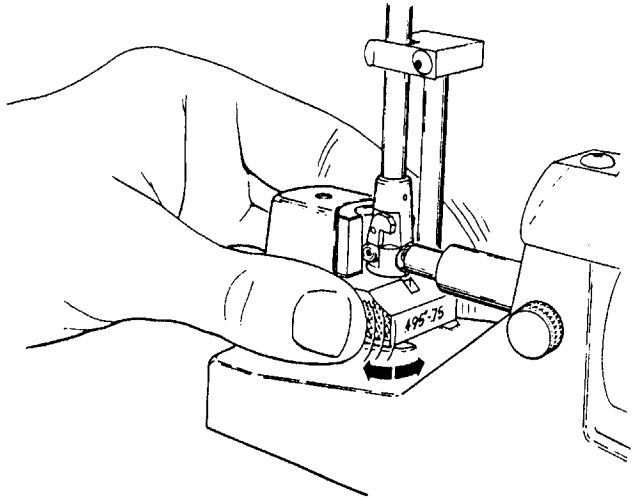

**FIGURE 11**

10. Rock the Nest in the horizontal plane (see Figure 11) until the Indicator Hand registers the minimum or "most minus" (-) reading.

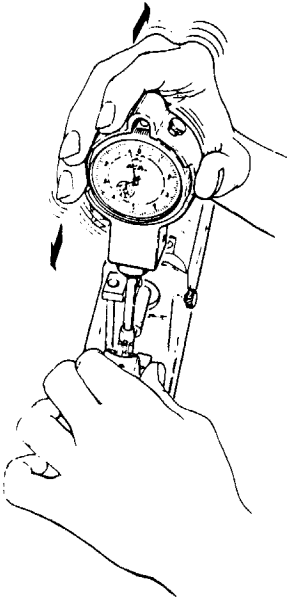

FIGURE 12

11. While holding the Nest stationary, rock the Gage in the vertical plane (see Figure 12) until the Indicator Hand registers the minimum reading. When using a GA-4000 or GR-6000 Series Gage, allow the Support Post Spring Finger to hold the Gage in the minimum reading position. Recheck the minimum reading in the horizontal plane. The Indicator Hand should now be within about  $30^{\circ}$  of the 12 o'clock position on the dial. If not, readjust the Gage Point until it is.

12. If the Indicator Hand **DOES** fall within about  $30^{\circ}$  of the 12 o'clock position, simply loosen the Bezel Screw and move the dial so the zero on the scale is aligned with the Indicator Hand. Then tighten the Bezel Screw. Recheck to be sure the Gage has not moved during this setting. If it has moved, repeat Steps 10, 11, and 12.
13. Remove the Gage from the Setting Fixture. The Gage is now set and ready for use.

### CHECKING THE CF-502 CALIBRATION

A .750'' diameter Master Ring is provided with the Sunnen CF-502 Setting Fixture. The CF-502 can be calibrated with this ring and either a Sunnen GA-4000 or GR-6000 Series Gage. A 1.190'' diameter Master Ring (CF-577) is available for calibrating the CF-502 with a GR-9000 Series Gage (diameter range: 1.180'' to 2.000''). However, any ring of known size within this diameter range can be used.

To check the calibration of the CF-502 Setting Fixture, proceed as follows:

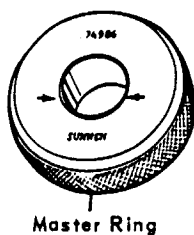

**FIGURE 13**

1. Remove the .750'' Master Ring from the case and clean it thoroughly. Note the arrows and, particularly, the size marked on it. See Figure 13.  
NOTE: **DO NOT** handle the ring excessively – an increase in temperature will change the size of the ring, thereby affecting the accuracy of the Setting Fixture.
2. Screw the correct Gage Point into the Gage.  
NOTE: If you are calibrating the CF-502 with a GA-4000 Series Gage, you would select Gage Point No. 3, which has a diameter range of .665'' to .750''. If using a GR-6000 Series Gage, you would select Gage Point No. 1, which has a diameter range of .740'' to .890''.
3. Place the Gage in the Master Ring so the Gage Point is aligned with one of the arrows marked on the ring.
4. Then, by adjusting the Gage Point in or out, set up the Gage so that zero on the Gage equals the size marked on the ring.

5. Select the correct Nest for the Gage you are using (refer to the marking on the Nest or to Table 2 below) and place it in the Setting Fixture.

Diameter Range Inches	Gage Series	Nest No.
.495 - .750	GA-4000	CF-550A
.740 - 1.190	GR-6000	CF-560A
1.180 - 2.000	GR-9000	CF-570A

Table 2

6. Place the Gage in the Nest and turn the Micrometer Spindle in until the Gage reads about plus .001.
7. Rock the Nest in the horizontal plane until the Indicator Hand registers the minimum or "most minus" (-) reading (see Figure 14).

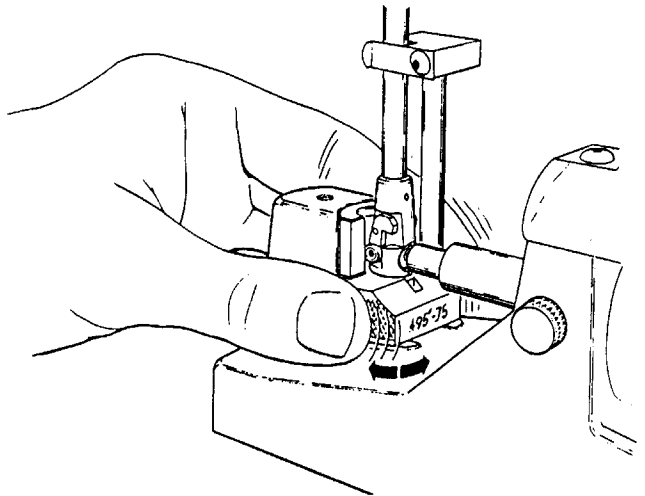

FIGURE 14

8. While holding the Nest stationary, rock the Gage in the vertical plane until the Indicator Hand registers the minimum reading (see Figure 15). Recheck the minimum reading in the horizontal plane.

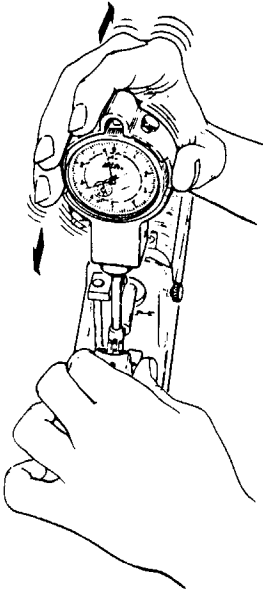
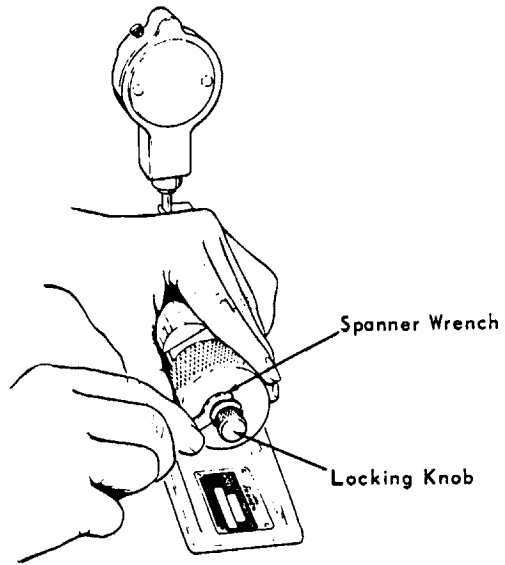

FIGURE 15

9. Turn the Micrometer Spindle in until the Gage reads zero.  
NOTE: Always set the Micrometer by moving from big to small. If you overshoot the desired setting, back up the Micrometer Spindle and reset.
10. Next, check the Micrometer Scale. It should read the same as the size marked on the Master Ring.  
NOTE: If the Micrometer Scale and Master Ring read the same, the Setting Fixture is in calibration and no further checking is necessary. If they are not the same, however, recalibrate as instructed in Steps 11 through 16 following.

11. With the Dial Bore Gage set at zero (Step 9 preceding page), lock the Micrometer Spindle with the Spindle Lock.
12. Holding the Micrometer Thimble, loosen the Locking Knob with the Spanner Wrench (CF-137A) provided. See Figure 16.



**FIGURE 16**

13. Set the Micrometer Thimble so the reading on the Micrometer Scale is the same as the size marked on the Master Ring.
14. Holding the Micrometer Thimble at this position, CAREFULLY turn the Locking Knob until it is finger tight. See Figure 17.

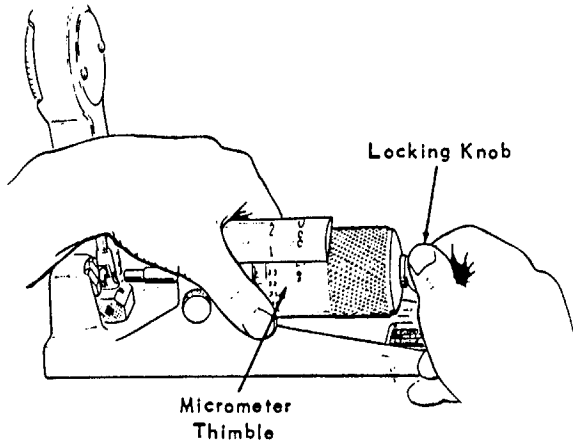

**FIGURE 17**

15. Holding the Micrometer Thimble, retighten the Locking Knob with the Spanner Wrench.
  16. Loosen the Micrometer Spindle Lock and reset the Micrometer to the same size marked on the Master Ring. The Dial Bore Gage should read zero. If it does not, repeat Steps 11 through 15.
- The CF-502 Setting Fixture is now calibrated and ready for use.







**SUNNEN PRODUCTS COMPANY**  
7910 Manchester Avenue  
St. Louis, Missouri 63143 U.S.A.  
Phone: 314-781-2100