



I-GR-6000B

OPERATING INSTRUCTIONS

SUNNEN DIAL BORE GAGE
SERIES MODEL GR-6000

DIAMETER RANGE:

.740'' - 1.190''



TABLE OF CONTENTS

	Page
Setting the Gage	4
Adjusting the Centralizer Points	13
Adjusting Worn Centralizer Points	15
Positioning the Indicator For Easier Reading	15
Replacing or Rotating A Worn Indicating Finger Ball	16
Calibrating the Sunnen Quick-Setting Wrench	19

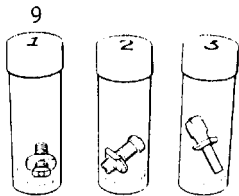
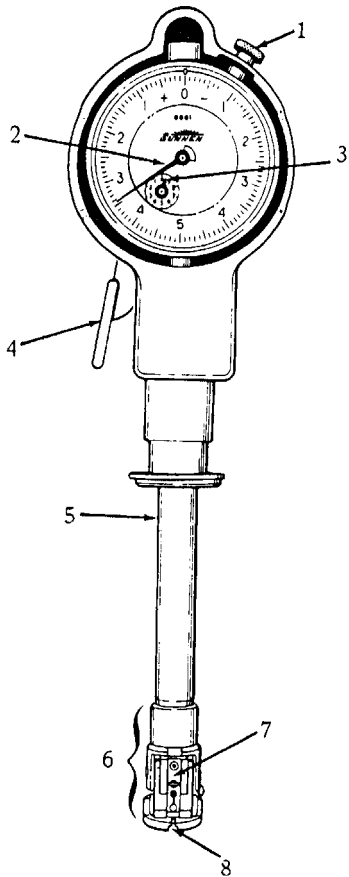

FIGURE 1

The Sunnen GR-6000 Series Retractable Dial Bore Gage (see Figure 1) includes the following components and accessories:

- (1) Bezel Screw;
- (2) Indicator Hand;
- (3) Counter Hand;
- (4) Retractor Lever;
- (5) Handle Extension;
- (6) Gage Head;
- (7) Indicating Finger;
- (8) Gage Head Keyway;
- (9) Gage Points with Lock Nuts;
- (10) Indicating Finger Clamp;
- (11) Indicating Finger Ball Tool;
- (12) Quick-Setting Wrench;
- (13) Three hex wrenches: $1/16''$, $3/32''$, and $1/8''$ (not shown).

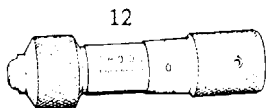
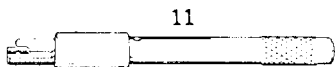
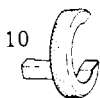

FIGURE 1 (cont'd)

SETTING THE GAGE

These instructions outline the setup of the Sunnen GR-6000 Series Dial Bore Gage with the Sunnen Quick-Setting Wrench and the Sunnen CF-502 Setting Fixture. The Quick-Setting Wrench is not intended to be a setting standard. However, it does provide a means of **PRESETTING** the Gage to within approximately .001" to .003" of size, and facilitates the handling and adjustment of the Gage Points.

1. Select the correct Gage Point using the information in Table 1. If, for example, the bore you are measuring has a .7950" diameter, you would use the Gage Point in Vial No. 1, which has a diameter range of .740" to .890".

Gage Point No.	Gage Point Length	Diameter Range Inches
1	.410"	.740 - .890
2	.560"	.890 - 1.040
3	.710"	1.040 - 1.190

Table 1

2. Examine the Quick-Setting Wrench. Note that the Lock Nut Drive slot is milled off center, making one lug larger than the other, and that the same is true concerning the Gage Point Drive slot. See Figure 2. Note also that the large lug of the Lock Nut Drive slot is in line with the Micrometer Scale of the Wrench (see Figure 3).

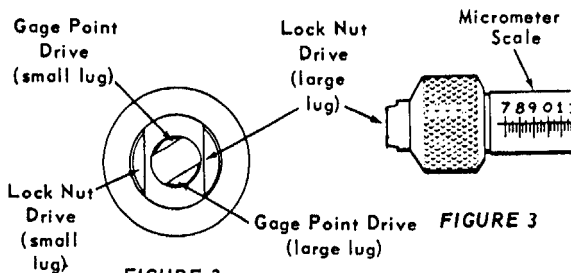

FIGURE 2

3. Now examine the Gage Point and Lock Nut Assembly. Note that the flats on both the Lock Nut and the end of the Gage Point are milled off center, making one flat larger than the other (see Figure 4).

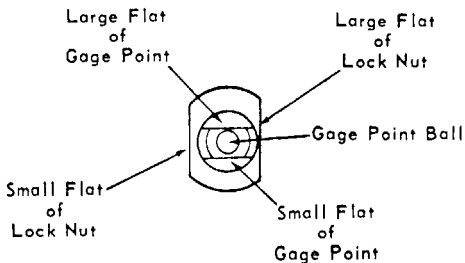

FIGURE 4

IMPORTANT: Note that one side of the Lock Nut has a large chamfer (see Figure 5). This chamfer must be installed toward the Gage Head.

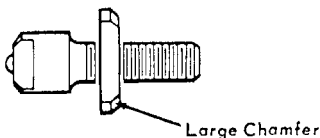

FIGURE 5

4. Install the Gage Point in the Dial Bore Gage as follows.
 - a. Slide the Adjusting Knob of the Quick-Setting Wrench all the way out (extreme open position). See Figure 6.

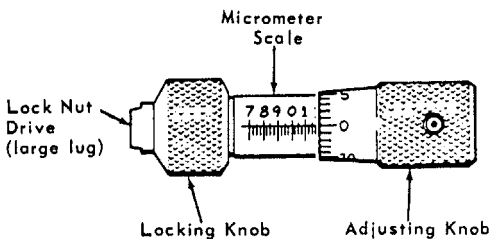

FIGURE 6

- b. Hold the Quick-Setting Wrench so the graduations on the Micrometer Scale are facing up. Insert the Gage Point (with the large flat of the Lock Nut facing up) into the Quick-Setting Wrench.
 - c. Slide the Adjusting Knob inward and turn slowly until the Gage Point Drive slot engages the flats on the Gage Point.
 - d. Hold the Quick-Setting Wrench at a slight angle, with the Gage Point upward. Screw the Gage Point into the Dial Bore Gage until the Lock Nut contacts the Gage Head. Do not tighten the Lock Nut.
 - e. Holding the Lock Nut in this position, turn the Adjusting Knob to the desired setting. Keep a light inward pressure on the Adjusting Knob while setting. Always come to the final setting while turning the Adjusting Knob in a clockwise direction (when viewed from the Adjusting Knob end).

- f. Tighten the Lock Nut by turning the Locking Knob and the Adjusting Knob at the same time, keeping just enough tension on the Adjusting Knob to maintain the micrometer setting.
- g. In the final calibration of the Dial Bore Gage (when using the Sunnen CF-502 Setting Fixture or a ring gage), the "0" point of the Indicator Hand may not be in the most desirable reading position. To change the position, place the Quick-Setting Wrench on the Gage Point and observe the micrometer reading. Then loosen the Lock Nut and turn the Adjusting Knob until the micrometer reading changes the amount you would like the Indicator Hand to move.

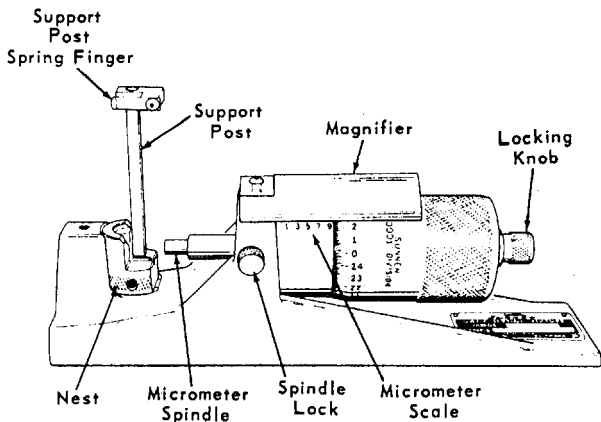

FIGURE 7

5. Select the correct Nest (refer to the marking on the Nest or to Table 2 below) and place it in the Setting Fixture (see Figure 7). The GR-6000 Series Gage will seat properly on only the CF-560A Nest.

Diameter Range Inches	Gage Series	Nest No.
.495 - .750	GA-4000	CF-550A
.740 - 1.190	GR-6000	CF-560A
1.180 - 2.000	GR-9000	CF-570A

Table 2

6. Be sure the Spindle Lock on the CF-502 is disengaged. Back off the Micrometer Spindle of the Setting Fixture to a point approximately .025" greater than the size being set.
7. **CAREFULLY**, place the Gage in the Nest so the Keyway in the Gage Head is aligned with the Key in the Nest (see Figure 8).

FIGURE 8

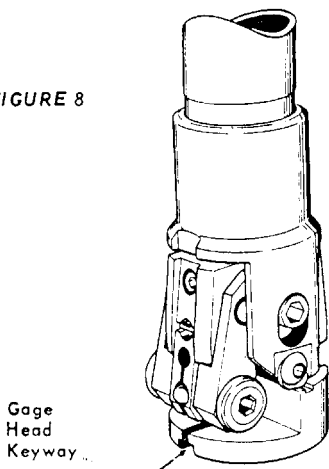

NOTE: The Gage will be held upright by the Support Post and Support Post Spring Finger, and the Gage Point should be toward the Micrometer Spindle (see Figure 9).

FIGURE 9

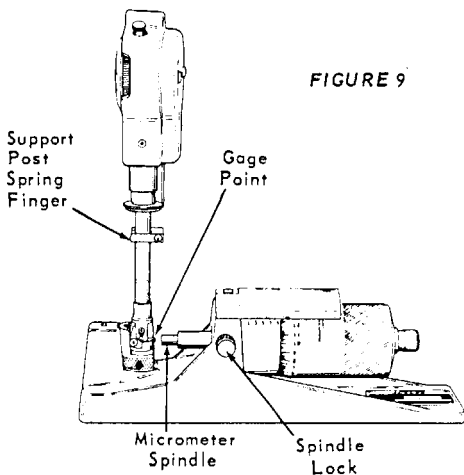

8. Turn the Micrometer Spindle in until it reads the exact size being set. Engage the Spindle Lock. The Micrometer Spindle should now be in contact with the Gage Point. **REMEMBER:** Always set the Micrometer by moving from big to small. If you overshoot the desired setting, back up the Micrometer Spindle and reset.
9. Be sure the Centralizer Points firmly contact the shoulders of the Nest (see Figure 10). **CAUTION:** If firm contact is not made, expand the Centralizer Points until firm contact is made. See Page 13 for instructions on Adjusting the Centralizer Points.

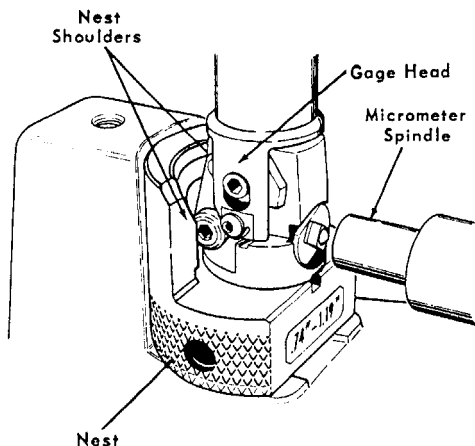

FIGURE 10

10. Rock the Nest in the horizontal plane until the Indicator Hand registers the minimum or "most minus" (-) reading (see Figure 11).

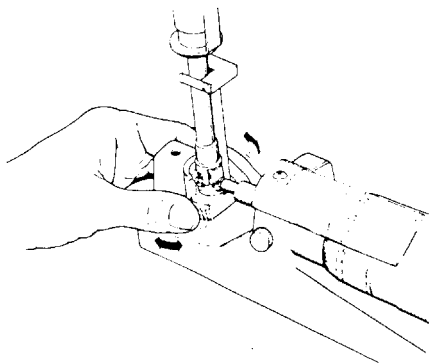

FIGURE 11

11. While holding the Nest stationary, rock the Gage in the vertical plane (see Figure 12) until the Indicator Hand registers the minimum reading. Then allow the Support Post Spring Finger to hold the Gage in that position. Recheck the minimum reading in the horizontal plane.
- NOTE: The Indicator Hand should now be within about 30° of the 12 o'clock position on the dial. If not, readjust the Gage Point until it is.

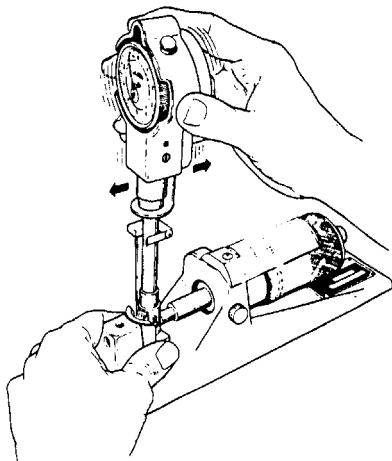

FIGURE 12

12. If the Indicator Hand falls within 30° of the 12 o'clock position, simply loosen the Bezel Screw and move the dial on the Indicator so the zero on the scale is aligned with the Indicator Hand. Then tighten the Bezel Screw. Recheck to be sure the Gage has not moved during this setting. If it has, repeat Steps 10, 11, and 12. The Gage is now set to size.

ADJUSTING THE CENTRALIZER POINTS

For maximum accuracy, the Centralizer Points should contact the wall of the bore firmly when they are set to size. You may adjust the Centralizer Points as described below.

1. Insert the long leg of a $1/16''$ hex wrench into the socket of the Centralizer Adjusting Cam (see Figure 13). Turn the hex wrench until the Centralizer Points are fully retracted.

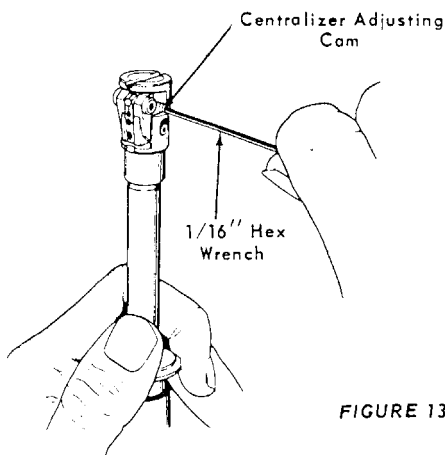
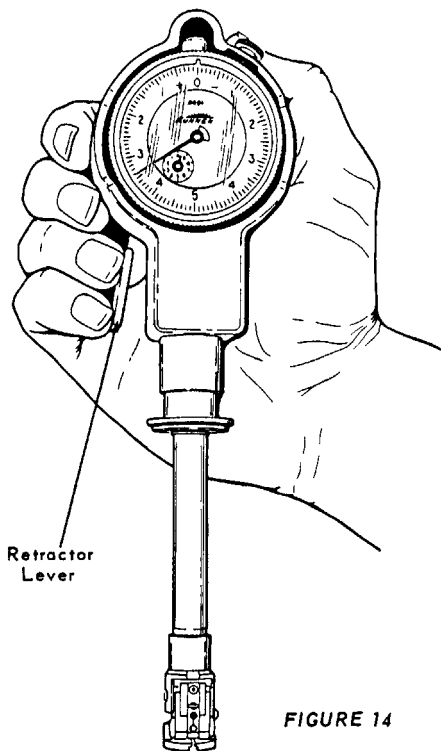

FIGURE 13

2. Leave the hex wrench in the socket and insert the Gage Head about $3/8''$ into the bore being measured.

3. With the Gage upright in the bore, turn the hex wrench until the Centralizer Points firmly contact the wall of the bore.



NOTE: To retract the Centralizer Points and the Indicating Finger, simply squeeze the Retractor Lever (see Figure 14).

ADJUSTING WORN CENTRALIZER POINTS

When the Centralizer Points must be adjusted because of excessive wear, be sure to adjust **BOTH** Points at the same time. Insert the long leg of a $1/16''$ hex wrench through **BOTH** Centralizer Points and turn **BOTH** Points at the same time until new wear surfaces contact the wall of the bore. See Figure 15.

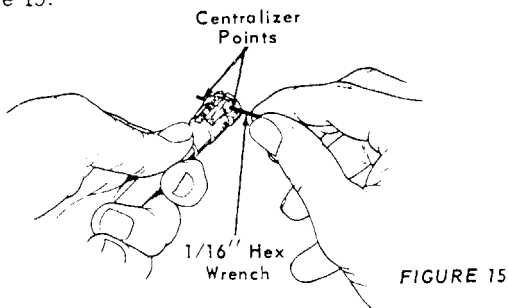

POSITIONING THE INDICATOR FOR EASIER READING

The Indicator Face can be indexed up to 90° in relation to the Gage Head, as described below.

1. Insert a $3/32''$ hex wrench into the access hole and loosen the Indicator Locking Screw no more than $1/2$ turn. See Figure 16.

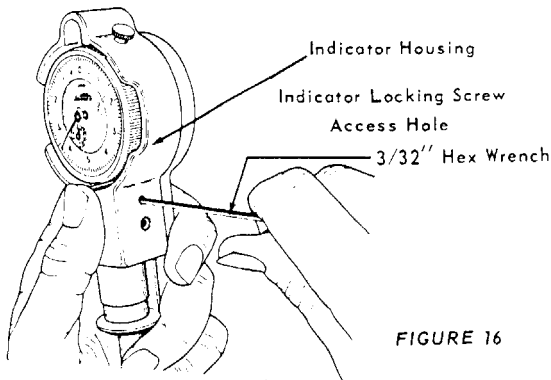

2. Rotate the Indicator Housing to the desired position.
3. Push the Gage Head and the Indicator Housing toward one another as far as they will go, and lock them in position firmly with the hex wrench. During this operation, the needle should move clockwise to about the 8 o'clock position.
NOTE: The Counter Hand indicates which turn or revolution the Indicator Hand is on. When the Gage is set properly and is at rest out of the bore, the Indicator Hand should be between the 7 o'clock and 9 o'clock positions and the Counter Hand should be just to the right of zero.

REPLACING OR ROTATING A WORN INDICATING FINGER BALL

When the Indicating Finger Ball becomes flat or worn, it can be replaced or rotated to a new position as described below.

1. Place a clean cloth under the Gage while removing and rotating the Ball.
2. Slip the Indicating Finger Clamp on the Handle Extension so the Lug fits snugly over the Indicating Finger of the Gage (see Figure 17).

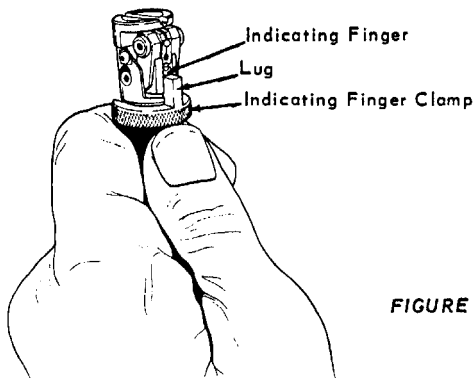
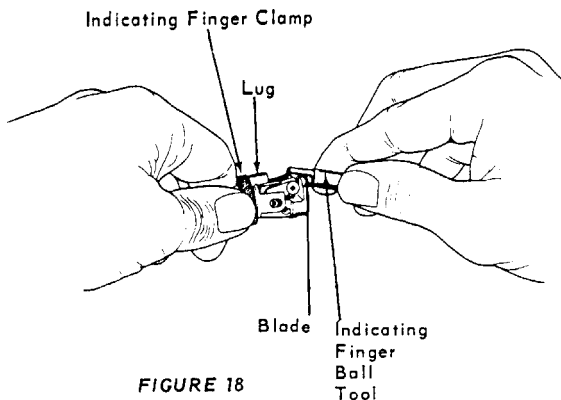

FIGURE 17

NOTE: The Indicating Finger Clamp restricts the movement of the Indicating Finger, thereby making it easier to remove and replace the Ball. The Clamp should be held against the Indicating Finger (see Figure 17) for the following steps.

3. Push the blade of the Ball Tool under the Ball through the slot in the Indicating Finger which intersects the ball socket. See Figure 18.



4. Pry up on the Ball until it snaps out of its socket. The Ball will be held between the blade and the Spring Clip of the Ball Tool (see Figure 18).
5. Rotate the Ball to a new position while it is held in the Ball Tool.
6. Press the Ball back into its socket with the Ball Tool.

7. Be sure the Ball is seated by pressing against it firmly with the back of the Ball Tool (see Figure 19).

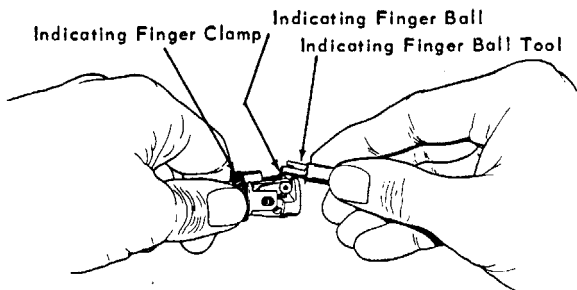

FIGURE 19

8. Remove the Indicating Finger Clamp.
NOTE: Before measuring the next workpiece, the Gage should be recalibrated with the Sunnen CF-502 Setting Fixture or a master ring of known size.

CALIBRATING THE SUNNEN QUICK-SETTING WRENCH

The Quick-Setting Wrench can be checked for calibration with the GR-6000 Series Dial Bore Gage and any ring gage of known size within the diameter range of .740'' to 1.190''. The Sunnen CF-502 Setting Fixture is provided with a .750'' diameter Master Ring which can be used for this purpose. The Quick-Setting Wrench may be calibrated as described below.

1. Install Gage Point No. 1 (diameter range .740'' to .890'') into the Dial Bore Gage. Set it to .750'' with the Quick-Setting Wrench.
2. Place the Gage in the .750'' diameter Master Ring. If the Quick-Setting Wrench is calibrated properly, the Indicator Hand should fall within 30° of the 12 o'clock position on the dial. If it does not, recalibrate the Wrench as described in Steps 3 through 7.
3. Place the Gage in the Master Ring and set the Gage to read zero. The size should be set so that zero falls at about 12 o'clock.
4. With the Quick-Setting Wrench in place on the Gage, loosen the Adjusting Knob Set Screw (see Figure 20) with a $1/16''$ hex wrench.

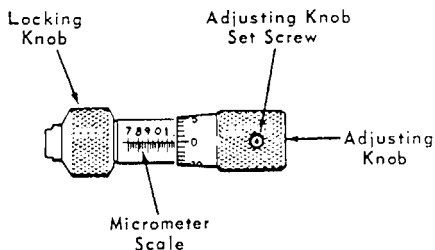

FIGURE 20

5. Turn the Adjusting Knob so the Micrometer Scale reads exactly .750.
6. Lock the Set Screw at the .750 reading.
7. Recheck the Gage in the Master Ring to confirm that the Gage is set correctly at .750.



SUNNEN PRODUCTS COMPANY
7910 Manchester Avenue
St. Louis, Missouri 63143 U.S.A.
Phone: 314-781-2100