



ABOVE AND BEYOND HONING

SV-30 SERIES

VERTICAL HONING MACHINES



250-20 UNC-2B
3 560 MIN FULL THREAD
4 800 MAX DRILL
5 $\sqrt{R} 275 \pm 0.15 \times 90^\circ$
6 $\sqrt{R} 0.125 \pm 0.015 \times 90^\circ$ (M)



SUNNEN'S SV-30 VERTICAL HONING MACHINE

POWERFUL, RUGGED AND PRECISE

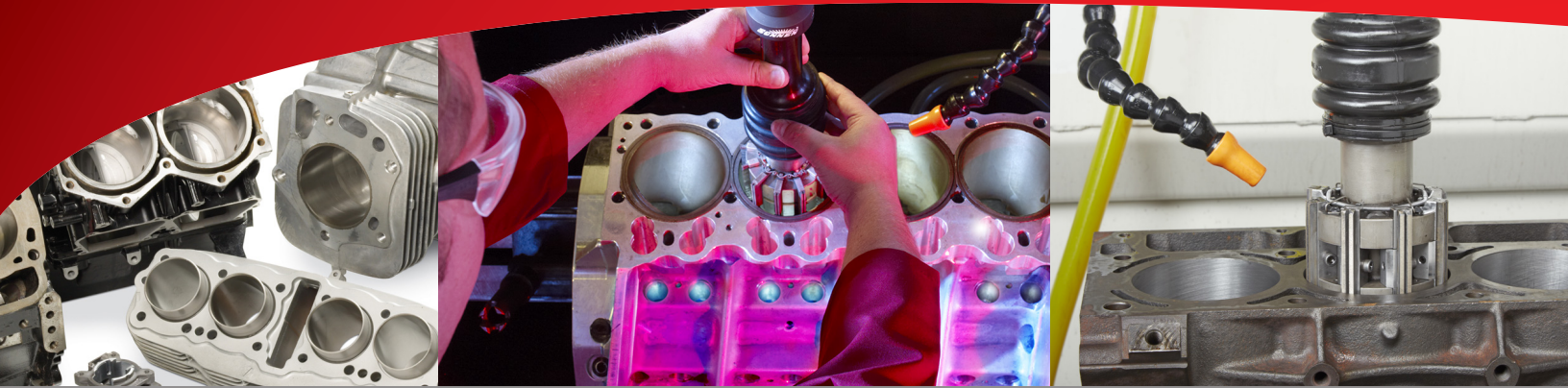

The SV-30 Series is the next generation of the legendary Cylinder King® line of honing machines known worldwide. The SV-30 series machines offer a wide variety of features and flexibility in an affordable package ideal for contract machine shops, automotive performance and rebuilding shops, and mid-volume industrial production facilities. There are six new standard SV-30 models with varying options assuring the right fit for virtually any mid-volume production industrial or automotive applications. Depending on the model, the SV-30 series includes such features as:

- New step and repeat functionality provides automatic bore-to-bore operation with servo X-axis and new GH LF series tooling.
- Tool protection at both top and bottom of the bore.
- Rugged cast iron column.





- Proven servo ball screw stroking mechanism.
- User-friendly Windows PC control with a large 378 mm (15") color touchscreen .
- CE compliant safety system standard on all models.
- All models feature Siemens and Phoenix industrial controls with software developed by Sunnen engineers who are experts in honing applications.
- For applications not requiring a high level of automation there are models offered with value-priced features such as an induction spindle and manual column movement.
- Backed by Sunnen's *best in the industry* 3-year parts and labor warranty and our extensive global field service support team.

Your Sunnen Technical Specialist will work with you to determine the best solution for your needs – it's all part of the added value you get with Sunnen. Plus, our worldwide sales and service team provides comprehensive support for the installation and operation of every system we make.

Whatever your need, we have the expertise and product range to create the right solution for you and the dedication to support you for the long run.

To find the Sunnen representative nearest you, visit our website:
www.sunnen.com

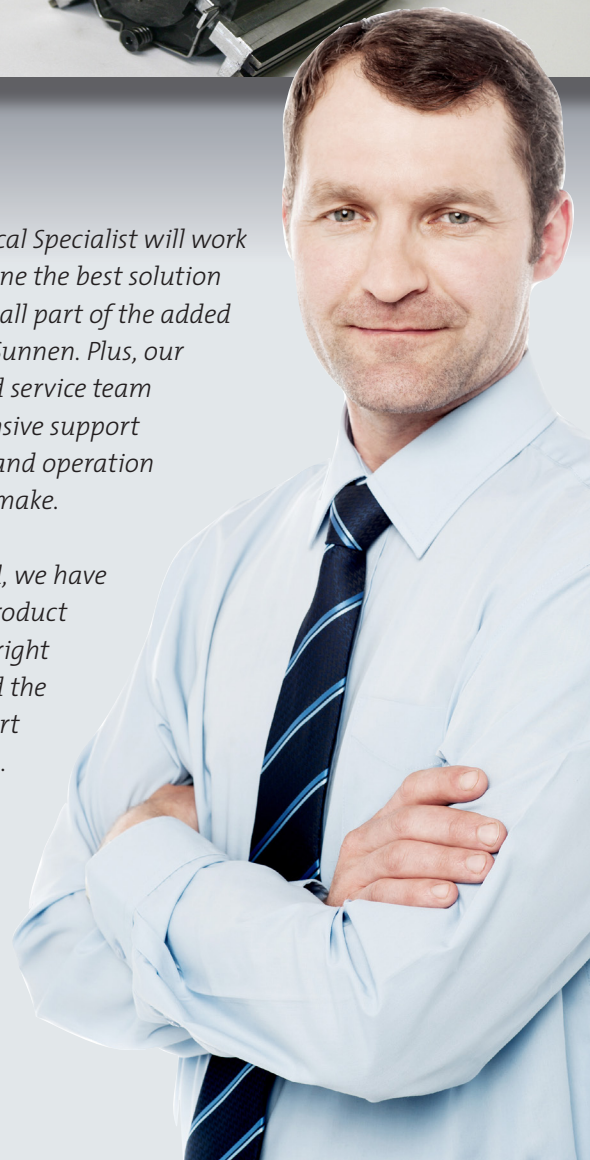

THE SV-30 DRIVES DIAMOND AND CBN ABRASIVES IN THE PRODUCTION, JOB AND PERFORMANCE SHOP.

STANDARD & OPTIONAL FEATURES

- Variable speed 50-600 rpm, 4.5 kW (6 hp) servo or 4.1 kW (5.5HP) induction spindle motors are powerful enough to drive two-stage, metal-bond, diamond and CBN abrasives for short cycle times with high accuracy and minimal labor.
- Heavy-duty cast iron column.
- The front loading design and weight capacity of up to 600 kg (1325 lbs), including fixture, combine for versatility in honing a wide range of parts.
- PC-controlled with a large 378 mm (15 in) color touch screen that is rugged and eliminates cumbersome buttons that collect oil, dirt and grime. The swiveling operator panel can be adjusted for viewing from a variety of positions.
- Servo or manual driven X-axis allows left/right positioning of the column with 813 mm (32 in) range
- Servo rotary tool feed system can be used with two-stage hone heads to complete roughing and finishing without stone changes for faster processing times. Rough to finish changeover is four times faster than previous models.
- Standard 206 liter (55 gallon) internal coolant system is equipped with two canister filters on the side of the machine, for ease of maintenance and provides increased coolant filtration for precise surface finish. Includes filter status indicator.
- Proven 2.5 kW (3.4 hp) servo ball screw stroking system allows for increased flexibility and performance.
- Heavy-duty welded base for durability.
- Standard LED work area lighting.
- Standard state-of-the-art CE compliant safety features include interlocked stainless steel sliding front panel, side and rear panels, front mounted light curtain, safety PLC, and safe limited setup speeds.
- MT Connect and Industry 4.0 capable.
- Standard PC uninterruptible power supply (UPS) eliminates unsafe shutdown of control system and ensures a safe start-up.





THE SV-30 PUTS YOU IN COMPLETE CONTROL FOR INCREASED PRECISION, CONSISTENCY, PRODUCTIVITY AND QUALITY



- **Full bore profile display** – projects a real-time display of the bore cross section that simplifies removing taper from the bore ... allows user to dwell in the exact position as long as necessary where bore is visually smaller – a Sunnen innovation.
- **Tool Protection** automatically checks the top and bottom of the bore prior to starting the cycle.
- **Size Lock** – allows you to hone to a preset diameter.
- **Rough and finish cycles** - rough cycle removes stock fast and can be set to automatically switch to finish cycle for optimum bore geometry and for the desired crosshatch angle.
- **Standard programmable Auto Dwell for unattended operation** - the machine automatically dwells in the tightest part of the bore – top, middle or bottom.
- **Advanced PC control** – allows variable speed for a much wider range of control and consistent crosshatch pattern. Switch from rough to finish honing with one push of a button.
- **Crosshatch control** – enter desired crosshatch angle and the machine automatically adjusts speeds to the entered angle.
- **Bore Oversize Setup** allows for fast setup for engine rebuilders in standard oversizes (Example: .010 in., .020 in., .030 in.)
- **Auto-reverse feature** allows fine-tuning of surface finish.
- **1000+** saved setup capability.
- **USB port** for software backup and updates.
- **SCREEN SELECTABLE LANGUAGES** include English, German, Spanish and Chinese.
- **More standard features** include short stroke, custom tool entry, and spindle load honing.

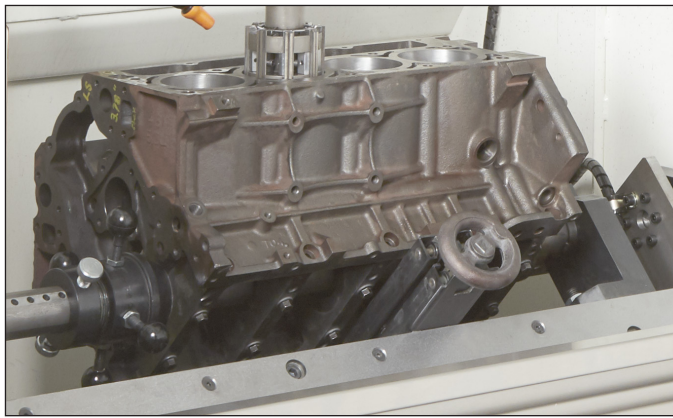

THE SV-30 FEATURES SUNNEN'S INNOVATIVE STEP AND REPEAT CAPABILITY

The SV-30 Series is capable of labor saving, automatic bore-to-bore operation (step and repeat) when equipped with a servo X axis. Models are available for both in line and V block configurations. For V block automatic operation the servo rolover cradle is required. This incorporates an innovative fixturing system to keep the tool and bore centerlines aligned. This feature requires use of the GH LF series of tools.

Machine Options include:

1. T-slot base plate for custom fixturing
2. Heavy-duty Manual Rollover Cradle for engine blocks accommodates in line and 60°/90°/120° V-type blocks. Special configurations are available. (pictured above). Both above options allow easy change over from cradle to T-slot)
3. Block Clamp Kit
4. 208/230 VAC Transformer
5. Full feature automation interface to reduce automation costs.

SV-30 WORK AREA AND DIMENSIONS

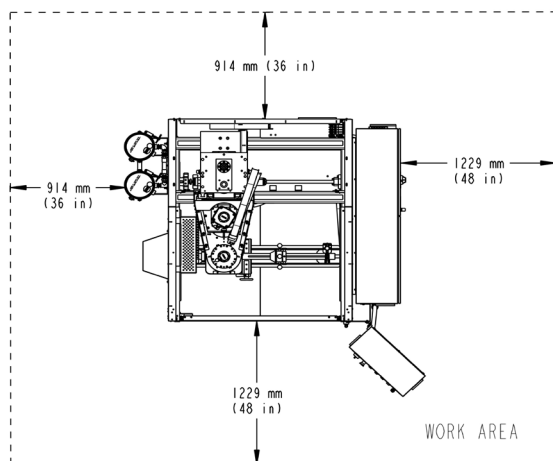

OVERALL MACHINE HEIGHT: 2853 MM (112.3 IN)
 OVERALL MACHINE WIDTH, SIDE: 2064 MM (81 IN)
 OVERALL MACHINE WIDTH, FRONT: 1831 MM (72 IN)

SPECIFICATIONS:

SPINDLE SPEED:

50 - 600 RPM

SPINDLE POWER:

4.1 kW (5.5 hp) - induction spindle models
 4.5 kW (6 hp) - servo spindle models

STROKER:

2.5 kW servo (3.4 hp)
 Variable speed: 5-100 SPM
 Stroke Length: up to 705 mm (27.75 in)
 Servo X Axis models: .5 kW (.67 hp)

CARRIAGE TRAVEL:

813 mm (32 in.) left/right travel available
 (X axis)

MAXIMUM WORKPIECE AND FIXTURE WEIGHT:

600 kg (1325 lbs)

WORKPIECE ENVELOPE:

1219 mm W x 760 mm D (48 in x 30 in)

MACHINE WEIGHT:

Dry Weight: 1329 kg (2930 lbs.)
 Shipping Weight: 1823 kg. (4020 lbs)

HONING FLUID/FILTER SYSTEM:

Honing Oil Reservoir: 206-liter
 (55-gallon) capacity with two standard
 canister filters.

VOLTAGES AVAILABLE

Electrical System:
 400 VAC 50 Hz 3 phase
 460 VAC 60 Hz 3 Phase

STANDARD SV-30 SERIES MODELS

SV-30: Manual X axis, 4.1 kW (5.5 hp)
 induction spindle

SV-30S: Manual X axis, 4.5 kW (6 hp) servo
 spindle

SV-30X: Servo drive X axis, 4.1 kW (5.5
 hp) induction spindle, step and repeat
 function - in Line

SV-30AX: Servo drive X axis, 4.1 kW (5.5 hp)
 induction spindle, Servo rolover cradle,
 step and repeat function - V block

SV-30SX: Servo drive X axis, 4.5 kW (6 hp)
 servo spindle, step and repeat function - in
 line

SV-30ASX: Servo drive X axis, 4.5 kW (6 hp)
 servo spindle, servo rolover cradle, step
 and repeat function - V block

SV-30 TOOLING, ABRASIVES AND LUBRICANTS

You get many tooling choices with the SV-30. It allows you to choose the exact tooling and abrasive to meet your specific production requirements and will use the same Sunnen tooling you've come to depend on. Sunnen is the only full-line company that produces its own precision honing abrasives. And with the largest variety of diamond or CBN superabrasives and aluminum oxide or silicon carbide conventional abrasives, you are assured of the most exact and consistent surface finish in the industry.

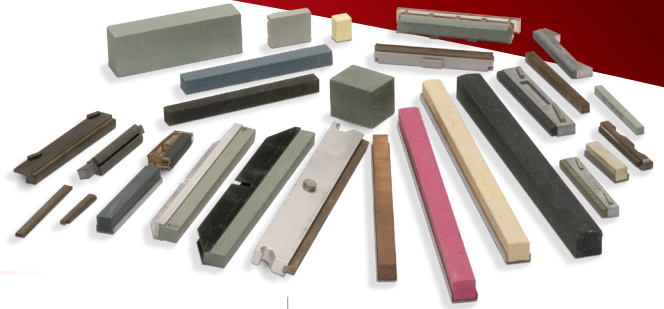

NOTE: All of the tools below are available for use in all SV-30 models unless using step and repeat. The GHSS LF Series and GHTS LF Series tools have been specially designed for use with the step and repeat feature.

GHSS/GHTS TOOLING

Sunnen's GHSS/GHTS multi-stone tools are designed for use with metal bond CBN and diamond abrasives for fast cutting action and reduced cycle times. Sunnen's Plateau Honing Tool (PHT) brushes work in these tools to provide consistent plateau finishes. The GHTS is a two-stage tool that performs both rough and fine honing operations (stone or brush) within the same honing tool – without changing stones – to reduce your bore sizing costs.

DH-SERIES DIAMOND HONING SYSTEM

Sunnen's Diamond Honing System features multi-point cutting action that spreads out force for faster, rounder bores and greatly improves productivity and performance. Three different tools cover the size range. An excellent choice for blind bores or ported cylinder heads.

SUNNEN CK/CV-TYPE TOOLING

Industry standard CK/CV-Type tools cut fast and are rugged, economical and easy to use. They have a large range, and the stones can be changed in seconds. Bores are finished faster and more accurately with minimum stock removal.

P20/P28 MANDRELS

These mandrels incorporate multiple stones aligned end-to-end to allow for long bore honing, with the P28 accommodating blind bore honing as well. Both P20 and P28 mandrels have replaceable abrasives and guide shoes. Requires CV-1010 adapter.

MPS/ANR MODULAR TOOLING

The MPS and ANR Tooling System can be used to convert any *big work* honing machine into a state-of-the-art bore finishing system. Allows you to hone a wide variety of materials, sizes and bore conditions quickly and economically.

BORE DIAMETER RANGE*:

GHSS: 37,59 - 140,71 mm
(1.48 - 5.54 inches)

GHTS: 62 - 140,7 mm
(2.44 - 5.54 inches)

BORE DIAMETER RANGE*:

70 - 139,7 mm (2.75 - 5.5 in.)

BORE DIAMETER RANGE*:

51 - 203 mm (2-8 inches)

BORE DIAMETER RANGE*:

P20: 19 mm - 25,4 mm
(.75 in - 1.00 in)

P28: 25,15 mm - 152,40 mm
(0.99 in - 6.00 in)

BORE DIAMETER RANGE*:

MPS: - 50 - 292,1 mm
(1.98 - 11.5 inches)

ANR: 64 - 533 mm
(2.5 - 21 in)

SUNNEN ABRASIVES AND LUBRICANTS

From aluminum oxide to silicon carbide to diamond and CBN, Sunnen offers the industry's largest variety of mounted or un-mounted stick abrasives, bond types, grain sizes and stone configurations.

Before any stone is shipped, it is graded and qualified, maintaining the most exacting quality control standards in the industry to assure you of the most consistent and precise honing performance available.

Sunnen's premium honing oils and coolants provide extreme lubricity for higher honing pressure and harder abrasives, delivering faster cutting rates, longer abrasive life, lower cost-per-part and ultimately more profits.

* Bore diameter ranges are for the standard tool series.

Special tools are available to extend this range but may be beyond the size capability of the machine.



A LEGACY OF EXCELLENCE SINCE 1924.

WORLDWIDE

Our global manufacturing, distribution, and sales and service network allows us to deliver quality Sunnen solutions worldwide.

And our state-of-the-art Technical Services Centers allow our technical experts to develop innovative solutions to customer application challenges. The Centers also provide answers for customer questions and training for Sunnen representatives around the world.

SUNNEN PRODUCTS COMPANY

WORLD HEADQUARTERS

St. Louis, MO – USA

Phone 1.314.781.2100

Fax 1.314.781.2268

Toll Free 1.800.325.3670

Email sunnen@sunnen.com
www.sunnen.com



AUSTRIA - SUNNEN AUSTRIA GMBH HOHENEMS

Phone +43 5576 74194

Fax +43 5576 74196

Email sales@sunnen.eu
www.sunnen.at

BELGIUM - SUNNEN BENELUX BVBA KONTICH

Phone +32 38 80 2800

Fax +32 38 44 3901

Email info@sunnen.be
www.sunnen.be

BRAZIL - SUNNEN DO BRASIL LTDA. SÃO PAULO

Phone +55 11 4177-3824

Fax +55 11 4362-3083

Email sunnen@sunnen.com.br
www.sunnen.com.br

CHINA - SHANGHAI SUNNEN MECHANICAL Co. LTD.

SHANGHAI

Phone +86 21 5813 3990

+86 21 5813 2299

Email shsunnen@sunnensh.com
www.sunnensh.com

CZECH REPUBLIC - SUNNEN S.R.O. STRAKONICE

Phone +420 383 376 317

Fax +420 383 376 316

Email sunnen@sunnen.cz
www.sunnen.cz

FRANCE - SUNNEN SAS

SACLAY

Phone +33 169 30 00 00

Fax +33 169 30 11 11

Email info@sunnen.fr
www.sunnen.fr

INDIA - SUNNEN INDIA PVT. LTD. MUMBAI

Phone +91 223 913 6055

Fax +91 223 913 6056

Email sales@sunnen.in
www.sunnen.in

ITALY - SUNNEN ITALIA S.R.L. ARESE

Phone +39 02 383 417 1

Fax +39 02 383 417 50

Email sunnen@sunnenitalia.com
www.sunnenitalia.com

POLAND - SUNNEN POLSKA Sp. z o.o. WARSAWA

Phone +48 22 814 34 29

Fax +48 22 814 34 28

Email sunnen@sunnen.pl
www.sunnen.pl

SUNNEN RUS LLC MOSCOW – RUSSIA

Phone +7 495 258 43 43

Fax +7 495 258 91 75

Email sunnen@sunnen-russia.ru
www.sunnen.ru

SWITZERLAND - SUNNEN AG ENNETAACH

Phone +41 71 649 33 33

Fax +41 71 649 33 34

Email sales@sunnen.eu
www.sunnen.eu

UK - SUNNEN PRODUCTS LTD. HEMPSTEAD HERTS

Phone +44 1442 39 39 39

Fax +44 1442 39 12 12

Email hemel@sunnen.co.uk
www.sunnen.co.uk

Sunnen reserves the right to change or revise specifications and product design in connection with any feature of our products contained herein. Such changes do not entitle the buyer to corresponding changes, improvements, additions, or replacements for equipment, supplies or accessories previously sold. Information contained herein is considered to be accurate based on available information at the time of printing. Should any discrepancy of information arise, Sunnen recommends that user verify the discrepancy with Sunnen before proceeding.