

MBB/MBC/EC/ML Series

Accessories and Supplies

EC-6550A Runout Indicator For EC, ML, KGM Machines



MBC-400A Runout Indicator For MBB/MBC Machines



KKN-100 Honing Fixture

A precision fixture for use when honing very short holes - where diameter of bore is more than three times the length, and the part has a flat face. Permits honing parts that otherwise are too short to be stabilized on the honing tool. Order face plates separately. Recommendation of Sunnen Field Engineer is suggested. Fits MBB-1650 and later models.
Shipping Weight: 35,7 kg (78.5 lbs.)



Accessories for Square Honing on Power-Stroke Machine KKN-615A Flex Pad can be used to hold part tight against faceplate.

KKN-265A Lineup Faceplate may be ordered for use as a fixture component.

EC-7100 Square Honing Fixture

This fixture is similar to the universal honing fixture which is supplied with the EC and ML Machines. The fingers move in the same scissors type motion as on the universal fixture. Also, the fingers automatically hold the workpiece against the faceplate with the start of the honing cycle and release at the end.

Accessories for Square Honing on ML Machine

EC-7150 Square Honing Conversion Kit:

This fixture kit will convert the standard universal fixture to the EC-7100 Square Honing Fixture.

EC-7080 Faceplate Mounting Kit:

The Mounting Kit consists of the parts required to fasten and adjust the faceplates on the stroker carriage. This new finger knob design allows for faster and easier adjustments of the faceplates. A mounting kit may be purchased for each faceplate to make changing setups faster.

EC-7000 Series Faceplates:

The EC-7000 Series Faceplates are a set of thirteen faceplates covering the same range as the KKN Faceplates. The faceplate numbers are as follows:

EC Series Faceplates for EC-ML Honing Machines				
Faceplate O.D.		Faceplate I.D.		Faceplate Number
mm	in.	mm	in.	
9,2	.362	5,5	.216	EC-7001\$
10,0	.398	6,3	.248	EC-7002\$
12,0	.472	7,8	.307	EC-7003\$
15,0	.590	10,0	.394	EC-7004\$
19,0	.750	13,4	.528	EC-7005\$
24,0	.945	17,0	.670	EC-7006\$
29,5	1.160	21,4	.843	EC-7007\$
37,0	1.457	26,9	1.060	EC-7008\$
44,2	1.740	33,0	1.300	EC-7009\$
53,0	2.087	39,9	1.570	EC-7010\$
63,0	2.480	44,7	1.880	EC-7011\$
71,6	2.820	56,3	2.220	EC-7012\$
81,0	3.190	65,7	2.590	EC-7013\$

NOTE: Request Product Bulletin #P-1153I on how to modify an EC Style Faceplate to fit the MBB & MBC Honing Machines.

\$NOTE: When ordering Faceplates for use on Precision Honing Machines, order one EC-7080 Square Honing Faceplate Mounting Kit and one KKN-260A Indicator Support Bar. (Only one Kit and Indicator Support Bar is required for all EC-7000 series faceplates. An EC-7080 Kit may be ordered for each faceplate, to make changing setup of faceplates on stroker carriage quicker).

EC-4500 Optional Automatic Size Control Unit For EC & ML Power-Stroke Honing Machines

The EC-4500 automatic size control unit attaches quickly and easily to ML honing machines. Features automatic positioning which moves the probe into position at the beginning of the honing cycle and retracted at the end of the cycle so that a new workpiece can be installed. Uses standard A.S.C. probes. (See page 8.4)
Shipping Weight: 52 kg (11 lbs.)

MB-2333A Extra-Long Offset Torque Bar 584 mm (23") Long

Useful for absorbing torque on workpieces which are too long for the standard 330 mm (13") torque bar. Easy to install in seconds.
Shipping Weight: 2,04 kg (4.5 lbs.)

Loop-Grip Holding Fixtures

Especially useful for hard-to-hold parts such as thinwall tubes, glass barrels, valve spools, small parts with smooth surfaces, and parts with sharp projections such as milling cutters. A must for absorbing torque on most Power Stroker jobs. Uses emery cloth to grip the part securely without distortion. Parts can be inserted and removed easily. Fixture handle rests on torque bar to absorb honing torque and reduce operator fatigue. Each fixture handles diameters as shown in chart (let out loop as needed).



Fixture Part Number Includes .9 m (3 ft.) of emery cloth	For Emery Cloth		Minimum Dimensions of Parts to be Honed				Replacement Emery Cloth 7,6 m (25 ft. Length)
	Width		Length		Outside Diameters		
	mm	in.	mm	in.	mm	in.	
HF-75	19,0	3/4	12,7	1/2	3,1	1/8	HF-110
HF-200	50,0	2	50,0	2	9,5	3/8	HF-210
HF-300	76,2	3	76,2	3	19,0	3/4	HF-310*
HF-355	Set of all three fixtures above.						

All others 240 Grit.

*NOTE: HF-320 Heavy Duty Abrasive Cloth 7,6 m (25 ft. length) is available for use in the HF-300 Holding Fixture and must be ordered separately. 120 Grit is more tear resistant and is suggested for those applications which use higher pressure control settings on the honing machine or where the rough hole in the workpiece makes the heavy duty cloth more desirable.

KKN-980 and KKN-990 Gimbal Fixtures

The Sunnen KKN-980 and KKN-990 Gimbal Fixtures attach to the Power Stroking Arm of any Sunnen Power Stroked Honing Machine. Used with a customer manufactured workholding fixture. Allows the workpiece to float freely on the mandrel, absorb torque, and provides ease in loading and unloading fixture. Refer to the following chart for workholding fixture design.



Model	Maximum Workpiece O.D.		Ring I.D.		Maximum Workholder O.D.		Maximum Pivot Pin Length		Pivot Pin O.D.	
	mm	in.	mm	in.	mm	in.	mm	in.	mm	in.
KKN-980	36,5	1 7/16	49	1 15/16	46	1 13/16	6,5	1/4	5	3/16
KKN-990	57,2	2 1/4	70	2 3/4	66	2 5/8	6,5	1/4	5	3/16

MBB/MBC/EC/ML

Accessories and Supplies

ADAPTERS & OTHER
ABRASIVES & TOOLING



MAN-700 Diamond Dresser

Essential to keep honing stones sharp and free cutting - saves time and labor costs. When cutting action of stone slows down, a light stroke with the Diamond Dresser breaks the glaze on the stone and restores honing efficiency. Especially recommended when honing hard alloy steels. (Not for use with CBN/Borazon or diamond honing stones.)
Shipping Weight: ,1 kg (.25 lb.)

MACHINE
ACCESSORIES

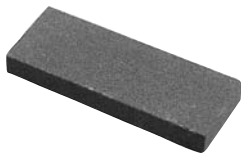

LBN-700 Abrasive Stick

(Silicon Carbide, 220 Grit)
For dressing CBN/Borazon and diamond honing stones only; for cleaning stones loaded with brass, bronze, or aluminum; for shaping a keyway stone; and for shortening a stone for blind hole work or to eliminate bellmouth. *Shipping Weight: ,1 kg (.25 lb.)*

GAGING

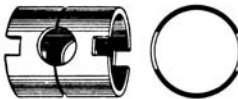

MBB/MBC Spindle Sleeves

Concentric
LN-570A Spindle Sleeve. Required for assembled P20 and smaller P28 type mandrels into spindle nose of MBB/MBC machine.
Shipping Weight: ,2 kg (.50 lb.)

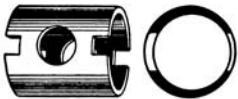

Eccentric
LN-0116A Spindle Sleeve. Similar in purpose to concentric sleeve above. Can be indexed to reduce mandrel runout in older machines equipped with non-adjustable spindle nose.
Shipping Weight: ,2 kg (.50 lb.)

FILTERS



Work Lights

Provide excellent glareless illumination. Completely adjustable. Mounts on Honing Machine. Supplied as shown with extension cord, on-off switch.

HS-15 For ML-/EC Honing Machines
MBC-200 For MBB Honing Machines

HONING FLUIDS
& COOLANTS



MB-2410 Work Tray

For MBB-1660. Package of 2. Attaches to left and right side of machine work tray. Keeps work area of machine free of parts while honing.
Shipping Weight: 6,1 kg (13.5 lbs.)

MB-2418A Replacement Pad for MB-2410 Tray. Package of one.
Shipping Weight: ,45 kg (1 lb.)

TECHNICAL DATA

Side Tray-EC/ML Machines

EC-6515A Side Tray
EC-6519A Replacement Mat for EC-6515A Side Tray EC/ML Machines

GH-80049 Truing Grit

Aids in truing in metal bond superabrasives. 70 grit (1pt.)

Replacement Belts for ML/EC

PDB-320A Stroker Belt All EC & ML Machines
PDB-206A Timing Belt All EC & ML Machines
PDB-326A Spindle Belt EC-3500 & ML-3500 Only
PDB-340 Spindle Belt for ML-2000, 4000 & 5000



For All MBC and MBB-1800 Power-Stroke Machines

MBB-1830A	Drive Motor Belt for 60 Hz machines	MBB-1840A	Spindle Drive Belt
MBB-1833A	Drive Motor Belt for 50 Hz machines	MBB-1823A	Brake Strap
		KKN-444A	Stroker Belt

For MBB-1690 Power-Stroke Machines

MBB-2620A	Drive Pulley V-Belt for Serial No. 82550 & Greater	MB-2292	Oil Pump Belt
MBB-2720A	Drive Pulley V-Belt for Serial Nos. prior to 82550	MBB-969A	Brake Strap Set
		KKN-444A	Gear Box Pulley Belt

For MBB-1660 Manual Honing Machines

MBB-2620A	Drive Motor Belt	MBB-969A	Brake Strap
MBB-910	Spindle Drive Belt	MB-2292	Pump Belt

Touch Up Paint

MBB-90437A Vista Green
MBC-90411A Pearl Grey
MBC-90412A Pewter Grey
Machine tool lacquer in 1 pint aerosol spray can.
Shipping Weight: ,45 kg (1 lb.)



NOTE: No longer available for export due to shipping restrictions for aerosol cans.

MB-2328C Replacement Anti-Splash Pads

MBB Honing Machines.
Package of 2 (upper and lower). *Shipping Weight: ,9 kg (2 lbs.)*

2.5X Magnifying Glass

Ground optical glass. Ideal for identifying numbers on small stones, for close examination of fine details, and for increased reading accuracy of Sunnen Precision Bore Gages, etc. Available in convenient leather case, or with spring clip for mounting on gage.

LN-150 Magnifying glass in leather case
Shipping Weight: ,1 kg (.25 lb.)

PG-25 Magnifying glass with spring clip
Shipping Weight: ,1 kg (.25 lb.)



LBN 462A Mandrel Wrench

For MBB/LBB/SV-10/SV-310
1/4" Hex Key and Wedge removal tool.

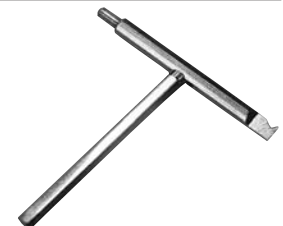

Hex Key Wrench Kits with Vinyl Pouch

PHS-50A 3/32, 3/16, 1/8, 5/32, 5/16, 5/64, 7/32, 1/4, 3/8, 7/64.
For MBB/LBB/SV-10 Machines.

PHS-50M 1.5, 2, 2.5, 3, 4, 5, 6, 8, 10 mm.
For SV-1000/SV-310.

MBB/MBC/EC/ML

Accessories and Supplies

KKN-750 Universal Honing Fixture

For MBB/MBC

Accommodates almost any workpiece or fixture. Easily and quickly installed or removed. Takes the thrust on forward and back strokes. Includes two pairs of fingers with long-wearing, adjustable carbide pads (including pair of KKN-720A Fingers at rear), two pairs of driving fingers for use with external hones, and 305 mm (12") long rods. (For longer workpieces, 457 mm (18") long KKN-778A Rods can be ordered separately.)

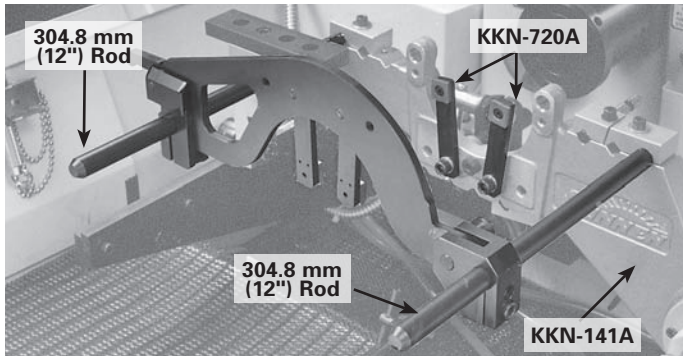

KKN-800 Part Support

Makes it easy to hone heavy workpieces on the MBB. The KKN-800 supports workpieces weighing up to 7 kg (15 lbs.), and is recommended whenever the size of the mandrel is too small to adequately support the workpiece being honed. The KKN-800 is quickly and easily attached to the stroking arm of the machine.

Shipping Weight:
7 kg (15 lbs.)

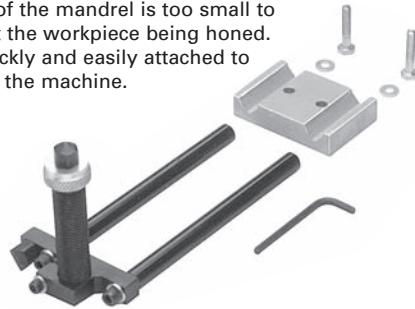

KKN-631A Part Support

Clamp Block with Four Screws and Washers

MMT/KRO Adapters for EC/ML

ML7210 Adapter Kit Consisting of Adapter/Alignment Bar, Collet Nut, Spanner Wrench and Extraction Tool.

NOTE: Either MMTSC1 or MMTSC2 Collet required for use of alignment bar.

NOTE: Must order tool collet separately -
MMTSC1 for 17mm shank tool,
MMTSC2 for 23mm shank tool,
MMTSC3 for 25mm shank tool,
MMTSC4 for 16mm shank tool,

EC-ND5X Part Support

For EC/ML Honing Machines

Similar to the KKN-800 Part Support. Allow 4 weeks for del.

Shipping Weight: 1 kg (2.2 lbs.)

EC-6031A Manual Torque Arm Kit-EC/ML

ML-6190

Standard Torque Arm

EC-7190 Long Fixture Support Bars

For EC/ML Machines

Attaches to the ML-6100 Stroking Arm of the EC/ML Machines and allows the honing of parts up to 357 mm (14") in length.

Shipping Weight: 1,5 kg (3.3 lbs.)

KKN-600 Honing Fixture for Small Parts

Accommodates most parts. Especially useful for small pieces. Easily and quickly installed or removed. Includes long-wearing, adjustable carbide pads on fingers, two pairs of support rods, and clamp. See photo to identify replacement parts.

Shipping Weight:
1,8 kg (4 lbs.)

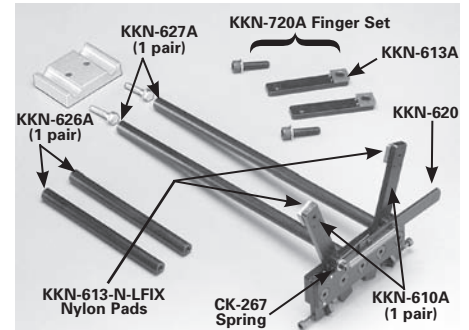

MBC-365 Fully Adjustable Spindle Nose Kit

For MBB-1660 Manual Honing Machines

Kit Includes:

Adjustable Spindle Nose, Spindle Nose Cover, Indicator and Mounting Hardware.

ADAPTERS & OTHER
ABRASIVES & TOOLING

MACHINE
ACCESSORIES

GAGING

FILTERS

HONING FLUIDS
& COOLANTS

TECHNICAL DATA

ASC

Sensing Units and Setting Fixture

For Use with EC-4500 Automatic Size Control Unit on EC/ML Machines

Automatic Size Control Sensing Tips 3,18 mm - 25,8 mm (1/8" - 1-1/64") Diameter Sensing Tips

Sensing Tips consist of a split plug with central adjusting screw. Adjustment compensates for wear—extends the life of the sensing tip. You can also use the same sensing tip for rough and finish honing. Useful diameter range is approximately .38 mm (.015"). Special probes are available for high production applications. Contact Sunnen Customer Service.



ASC-0500 Sensing Tip

Sensing Units and Setting Fixture

26 mm - 51 mm (1" - 2") Diameter

The ASC-50 Micrometer-Type Setting Fixture is used to set the four radial adjusting screws centrally and to rough size. Final setting is accomplished by adjusting center screw in the split plug body.



ASC-51 Sensing Unit



ASC-50 Setting Fixture

Sensing Unit Part Number	Diameter Range	
	mm	in
ASC-51	26 - 32	1 - 1 1/4
ASC-52	32 - 38	1 1/4 - 1 1/2
ASC-53	38 - 45	1 1/2 - 1 3/4
ASC-54	45 - 51	1 3/4 - 2

Sensing Tip Part No.	Nominal Diameter		Diameter Range			
	mm	in	Low		High	
ASC-0125	3,18	1/8	3,05	.120	3,53	.139
ASC-0141	3,57	9/64	3,42	.135	3,91	.154
ASC-0156	4	5/32	3,81	.150	4,29	.169
ASC-0172	4,36	11/64	4,22	.166	4,70	.185
ASC-0188	4,76	3/16	4,57	.180	5,05	.199
ASC-0203	5	13/64	4,85	.191	5,33	.213
ASC-0219	5,56	7/32	5,36	.211	5,84	.230
ASC-0234	6	15/64	5,74	.226	6,22	.245
ASC-0250	6,35	1/4	6,10	.240	6,58	.259
ASC-0266	6,75	17/64	6,50	.256	6,99	.275
ASC-0281	7	9/32	6,83	.269	7,32	.288
ASC-0297	7,54	19/64	7,29	.287	7,77	.306
ASC-0312	8	5/16	7,72	.304	8,20	.323
ASC-0328	8,33	21/64	8,08	.318	8,56	.337
ASC-0344	8,73	11/32	8,48	.334	8,97	.353
ASC-0359	9	23/64	8,81	.347	9,30	.366
ASC-0375	9,53	3/8	9,27	.365	9,75	.384
ASC-0391	10	25/64	9,73	.383	10,21	.402
ASC-0406	10,32	13/32	10,06	.396	10,54	.415
ASC-0422	10,72	27/64	10,47	.412	10,95	.431
ASC-0438	11	7/16	10,82	.426	11,30	.445
ASC-0453	11,51	29/64	11,25	.443	11,74	.462
ASC-0469	12	15/32	11,71	.461	12,19	.480
ASC-0484	12,3	31/64	12,04	.474	12,52	.493
ASC-0500	12,7	1/2	12,45	.490	12,93	.509
ASC-0516	13	33/64	12,83	.505	13,31	.524
ASC-0531	13,50	17/32	13,23	.521	13,72	.540
ASC-0547	14	35/64	13,72	.540	14,20	.559
ASC-0562	14,29	9/16	14,02	.552	14,50	.571
ASC-0578	14,68	37/64	14,43	.568	14,91	.587

Sensing Tip Part No.	Nominal Diameter		Diameter Range			
	mm	in	Low		High	
ASC-0594	15	19/32	14,81	.583	15,29	.602
ASC-0609	15,48	39/64	15,22	.599	15,70	.618
ASC-0625	15,88	5/8	15,62	.615	16,10	.634
ASC-0630	16		15,75	.620	16,23	.639
ASC-0641	16,27	41/64	16,03	.631	16,51	.650
ASC-0656	16,67	21/32	16,41	.646	16,89	.665
ASC-0672	17	43/64	16,79	.661	17,27	.680
ASC-0688	17,46	11/16	17,22	.678	17,70	.697
ASC-0703	18	45/64	17,70	.697	18,19	.716
ASC-0719	18,26	23/32	18,01	.709	18,49	.728
ASC-0734	18,65	47/64	18,39	.724	18,87	.743
ASC-0750	19	3/4	18,80	.740	19,28	.759
ASC-0766	19,45	49/64	19,20	.756	19,69	.775
ASC-0781	20	25/32	19,69	.775	20,17	.794
ASC-0797	20,24	51/64	19,99	.787	20,47	.806
ASC-0812	20,64	13/16	20,37	.802	20,85	.821
ASC-0828	21	53/64	20,78	.818	21,26	.837
ASC-0844	21,43	27/32	21,18	.834	21,67	.853
ASC-0859	22	55/64	21,67	.853	22,15	.872
ASC-0875	22,22	7/8	21,97	.865	22,45	.884
ASC-0891	22,62	57/64	22,38	.881	22,86	.900
ASC-0906	23	29/32	22,76	.896	23,24	.915
ASC-0922	23,42	59/64	23,17	.912	23,65	.933
ASC-0938	24	15/16	23,67	.932	24,16	.951
ASC-0953	24,21	61/64	23,95	.943	24,44	.962
ASC-0969	24,61	31/32	24,36	.959	24,84	.978
ASC-0984	25	63/64	24,69	.972	25,17	.991
ASC-1000	25,40	1	25,15	.990	25,63	1.013
ASC-1016	26	1-1/64	25,68	1.011	26,16	1.030

ASC-10 For a complete set of the above Sensing Tips.
Covers the diameter range: 3,18 mm - 25,8 mm (1/8" - 1-1/64").

Alignment Bushings

For Mandrel Centering with adjustable spindle nose

Accurate centering of the mandrel requires a concentric bushing whose I.D. falls within the finish bore limits of the workpiece. **Sunnen truing sleeves are not suitable for this purpose.** Table at right lists the bore diameter and part number of standard alignment bushings.

For bores whose finish size falls between the diameters listed in the table, select the bushing whose bore diameter is just *under* finish size. When setting up the job for the first time, the undersize alignment bushing can be honed out to finish size with the same tooling used for honing the workpiece. For bushing diameters outside the standard range, call your Sunnen representative.

Part No.	Bore Size mm	Bore Size in	Part No.	Bore Size mm	Bore Size in	Part No.	Bore Size mm	Bore Size in	Part No.	Bore Size mm	Bore Size in	Part No.	Bore Size mm	Bore Size in
C-100	2,54	.100	C-160	4,06	.160	C-250	6,35	.250	C-354	8,99	.354	C-619	15,72	.619
C-102	2,59	.102	C-165	4,19	.165	C-255	6,48	.255	C-362	9,19	.362	C-625	15,88	.625
C-104	2,64	.104	C-170	4,32	.170	C-260	6,60	.260	C-370	9,40	.370	C-650	16,51	.650
C-106	2,69	.106	C-175	4,45	.175	C-265	6,73	.265	C-375	9,53	.375	C-681	17,30	.681
C-108	2,74	.108	C-180	4,57	.180	C-270	6,86	.270	C-385	9,78	.385	C-687	17,45	.687
C-110	2,79	.110	C-187	4,75	.1875	C-275	6,99	.275	C-400	10,16	.400	C-713	18,11	.713
C-112	2,84	.112	C-190	4,83	.190	C-280	7,11	.280	C-416	10,57	.416	C-750	19,05	.750
C-114	2,90	.114	C-195	4,95	.195	C-285	7,24	.285	C-432	10,97	.432	C-812	20,62	.8125
C-116	2,95	.116	C-200	5,08	.200	C-290	7,37	.290	C-437	11,10	.4375	C-875	22,22	.875
C-118	3,00	.118	C-205	5,21	.205	C-295	7,49	.295	C-447	11,35	.447	C-937	23,80	.937
C-120	3,04	.120	C-210	5,33	.210	C-300	7,62	.300	C-463	11,76	.463	C-1000	25,40	1.000
C-125	3,18	.125	C-215	5,46	.215	C-308	7,82	.308	C-479	12,17	.479	C-1062	26,97	1.0625
C-130	3,30	.130	C-220	5,59	.220	C-312	7,92	.312	C-495	12,57	.495	C-1125	28,58	1.125
C-135	3,43	.135	C-225	5,72	.225	C-316	8,02	.316	C-500	12,70	.500	C-1187	30,15	1.1875
C-140	3,56	.140	C-230	5,84	.230	C-323	8,20	.323	C-526	13,36	.526	C-1250	31,75	1.250
C-145	3,68	.145	C-235	5,97	.235	C-331	8,40	.331	C-557	14,13	.557	—	—	—
C-150	3,81	.150	C-240	6,10	.240	C-339	8,61	.339	C-562	14,27	.5625	—	—	—
C-155	3,94	.155	C-245	6,22	.245	C-347	8,81	.347	C-588	14,93	.588	—	—	—

ADAPTERS & OTHER ABRASIVES & TOOLING

MACHINE ACCESSORIES

GAGING

FILTERS

HONING FLUIDS & COOLANTS

TECHNICAL DATA

Replacement Belts

PDB-337	Spindle Belt (KGM-5000)
PDB-327	Spindle Belt (KGM-1000)
PDB-336	Stroker Belt (KGM-1000/5000)
PDB-318	Drive Belt (1000/5000)



KGM Spindle Wrench

PWM-300	Torque Wrench
PWM-301	Wrench Head
PWM-302	Spanner Wrench
EC-6550A	Spindle Runout Indicator

Replacement Fixturing Air Lines

5/32" O.D.

(Sold in 304,8 mm [12"] length only.)

78156A	White	78160A	Yellow
78157A	Black	78161A	Orange
78158A	Red	78162A	Green
78159A	Blue		

CGM-4491A Air Line Retainers with Screw

MMT Adapter

Allows for installation of MMT tooling to KGM

MMT-KGM81A	17mm shank MMT
MMT-KGM82A	23mm shank MMT
MMT-KGM83A	25mm shank MMT

Includes Collet, Collet Nut, Spanner Wrench, Extraction Tool, Wedge Coupler, Spindle Adapter.

(Prior to selecting tooling and adapters, consult with a Sunnen Application Expert.)

Coolant Accessories

CGM-3205A	Coolant Nozzle Set
CGM-3201A	Coolant Hose 914,4 mm (3 ft.)

Lubricating Oils KGM-5000

SML-10 Spindle Oil
(Mobil SHC-626) ,47 liter (1 Pint)

Lubricating Grease for KGM-5000

SML-170 Lubricating Grease
Lubricating Grease for KGM-5000 (Polyrex Em)
,41 liter (14 oz.) Tube

SML-100 Lubricating Grease
(MobilTemp™ SHC-32 or MobilGrease™ 28)
,41 liter (14 oz.) Tube

Note: Use of any other oils or lubricants will cause component failure.



Optional Fixturing for KGM-5000 KROSSGRINDING® Machine

CGM-4200 Automatic Finger Fixture

The air-actuated CGM-4200 Automatic Finger Fixture is a versatile fixturing system that can be used for either manually loading or automating the KGM Machine.

CGM-4210A

Air-Actuated Finger Assembly

Used in place of CGM-4201A Fixed Finger Set.

CV616/SV-10

Accessories and Supplies

ADAPTERS & OTHER
ABRASIVES & TOOLING

SV-10 Replacement Belts

Part Number	Description
PDB-341	Stoker Drive Belt
PDB-342	Spindle Drive Belt
CK-252	Timing Belt

CV-616 Replacement Belts

Part Number	Description
CK-252A	Timing Belt
CK-192A	Flat Belt
CK-209A	"V" Belt, Upper
CK-498A	"V" Belt, Lower



CV-1100 Fiber Mats

These mats remove the coarse swarf produced during honing before it enters the machine sump. They extend the time between cleaning the machine sump and also extend filter and pumping system life. Five to the standard package. Measures 134 x 86 cm (53" x 34").

Feed System-CV-616/SV-10

CK-125A Feed Ratchet Pawl Replacement Kit

Replaces work Feed Ratchet Pawl.

CV-616-HN2X 1/2 Rate Pawl Kit

Reduces feed rate by 1/2 for applications (superabrasives and carbide or tool steel) which the standard feed rate does not advance slow enough for wear and load builds. Replaces standard on machine feed pawls.



CK-234A Gear Set

Replacement Fiber planetary gear set for the CV-616/SV-10 handwheel assembly.

Cover for Operator Station Screen — SV-10

CV-605B

Replacement protective cover for screen.

PF-244A

Gasket for filter canister lid CV616/SV-10.

Stroke Scale Plates

CV616/SV-10

Stroke Scale Plates for CV-616 Cylinder King

Part Number	Stone Length
PNP-12752	3/4" (69, 8 mm)
PNP-13503	1/2" (88, 9 mm)
PNP-14504	1/2" (114, 3 mm)
PNP-1600	6" (152, 4 mm)
CV-1285 (not shown)	9" (228, 6 mm)

For metric, add "M" to the part number.

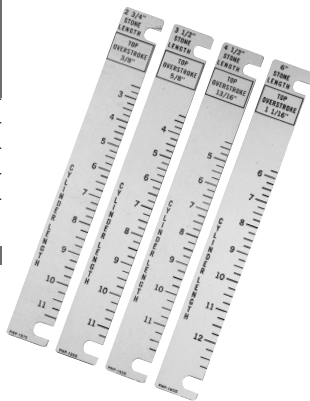

MACHINE
ACCESSORIES

SV10 Replacement Belts

Part Number	Description
CK-125A	Ratchet Pawl Replacement Kit
CV-616-HN2X	1/2 Rate Pawl Kit
CV-605B	Replacement Protective Cover for SV-10 Operator Screen

CK-3410A Lamp and Bracket Assembly

The CK-3410A is equipped with an 8-foot long cord with moulded on ground plug. It is offered in 115 volt, single phase only and will plug into any standard 3-wire convenience outlet. The unit is supplied with a clamp for attachment to the control station arm. (Takes 100 watt maximum incandescent bulb; bulb not included.)
Shipping Weight: 3,2 kg (7 lbs.)



CK-448A Gearbox Oil

CK-448A is a sulphur free gearbox lubricant used in the CV-616/SV-10 transmission case. Use of 90 weight hypoid lubricant will cause premature gearbox wear and is not recommended.



GAGING

FL6X-20 MPS or Portable Tooling Adapter for CV-616/CK-21/SV-10

For use on applications larger than 8" in diameter or for parts with keyways, ports or other interruptions where standard CV/CK tooling will not work. Order MPS or ANR hone heads separately - Special Order. Please call Sunnen for availability.
Shipping weight: 3 kg (6.5 lbs.)



FLX6X-20 shown with MPS-H70 Hone Head.

FILTERS

CV-1010 Mandrel Adapter

The CV-1010 adapts standard mandrels in applications where the standard hone heads do not apply. Minimum diameter 19 mm (.75"). Mandrel not included.
Shipping Weight: 2,3 kg (5 lbs.)



CV-1010 shown with 2G-P28-2000WF Mandrel.

HONING FLUIDS
& COOLANTS

CV-271A Over Arm Counterbalance Weight Block

For CV-616 Serial No. 4358 and above. Order when using large hone heads, large P28 and Y mandrels. Helps keep head in position when tool is removed from bore.
Does not fit SV10 Machines.

CV-1220A Cradle Counterweight Kit

Attached to the CV-616/SV-10 cradle, this kit reduces the effort required to shift the cradle when changing from its vertical or horizontal positions.

TECHNICAL DATA

SV-1000/2000 Series

Tooling Adapters and Accessories

Tooling Adapters

NOTE:

Tooling selection is application dependent. Prior to selecting tooling and adapters, consult with a Sunnen application expert.

MMT

Part Number	Description
MMT-SCN	Collet Nut
MMT-SCE	Collet Extractor
MMT-SCW	Collet Nut Wrench
MMT-SC1	17mm Tool Shank Collet
MMT-SC2	23mm Tool Shank Collet
MMT-SC3	25mm Tool Shank Collet
MMT-SC4	16mm Tool Shank Collet
SV-39150	Runout Adjustable Collet Adapter (for use with MMT-SCX collets)
SV-39170	Runout Adjustable Large MMT Adapter (50mm shank)
SV-39210	Floating Tool Holder - MMT Up to 17mm Shank
SV-39220	Floating Tool Holder - MMT Up to 25mm Shank

CGT

Part Number	Description
SV-39010	CGT Spindle Adapter
PWM-300	Torque Wrench (pre set to 45 ft-lbs)
PWM-301	7/8" Wrench Head (for use with PWM-300)
PWM-306	Hook Spanner

Single Stroke

Part Number	Description
SV-39230	Floating Tool Holder for Single Stroke Tooling

Standard Tooling - K, KR, L, LR, BL, D2, JK, AK, Y, P20, P28

Part Number	Description
SV-39030	Standard Tooling Adapter

Spindle Tool

Part Number	Description
SV-39080	Used to Remove Ball Coupler for CGT Installation and to Lock Spindle While Tightening MMT Collet Nut

Tool Alignment Indicator

Part Number	Description
SV-39040	Mounts to column

Work Area Light Kit

VSS-29050

SV-400/2400 Series

Accessories

CV-1010

Mandrel Adapter (same as SV-10) - Adapts standard mandrels to spindle

SV-21110

Fixture Frame for Mounting Custom Work Piece Fixtures

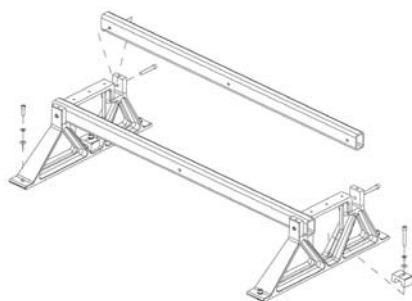

NOTE: SV21115 fixture frame is available for SV410/2410 machines and includes T-slot base

SV-51117

T-Slot Table — Mounts to Base of Machine. Allows for Use of T-Nuts to Mount Work Piece Fixtures. Optional for SV410/2410 only.

VSS-29050

Work Area Light Kit

Item Number	Order by Part Number	QTY.	Description
-	SV-21110	-	- Fixture Frame, Optional includes
1	PHSM-452	4	- Screw, M12 x 1.75 x 35mm SHCS
2	PHSM-809	6	- Screw, M12 x 80mm SHCS
3	PHWM-408	6	- Lockwasher, M12
4	PHWM-549	6	- Flatwasher, M12
5	SV-21102	2	- Fixture Support
6	SV-21103	2	- Fixture Anchor
7	SV-26093	2	- Rail
Optional	SV26220	1	Servo Rollover Cradle (2) SV21102 fixture supports
Optional	SV26250	1	Man. Rollover Cradle (2) SV21102 fixture supports
Optional	CK6200	-	Clamp Kit can be used with any of these fixtures

SV-1000/2000/400/2400 Series Maintenance

ADAPTERS & OTHER
ABRASIVES & TOOLING

SV-1000/300/400 Maintenance

Part Number	Description
90123	Ball Screw Grease - Kluberplex 1 kg Can (SV-1000/310)
SV-32820A	Replacement Way Cover (SV-1000/310)
PFC-150-1	Replacement Air Filter for MVH-7120 Air Unit

Belts

Part Number	Description
SV-23119	SV-310 Motor Belt (upper)
SV-23118	SV-310 Spindle Belt (lower)
PDB-217	SV-1000 Series Spindle Motor & Ball Spline Belt (2 REQD per column)

MACHINE
ACCESSORIES

VSS & VSS Series 2

GAGING

Tooling Adapters (VSS and VSS Series 2)

Part Number	Description
VSS-9110	Runout Adjustable Spindle Adapter
VSS-9115	Floating Tool Holder Adapter

Work Area Light Kits

VSS-6170	for VSS Machines
VSS-29050	for VSS Series 2 Machines

Tool Alignment Indicator

SV-39040 for VSS Series 2

FILTERS

Maintenance

HOVING FLUIDS
& COOLANTS

Belts

VSS:	
Part Number	Description
PDB-215	Column Timing Belt VSS-84/64/86
PDB-107	Intermediate Spindle Drive Belt VSS-86
PDB-106	Main Spindle Drive Belt VSS-86

VSS Series 2:

Part Number	Description
PDB-220	Spindle Drive Belt VSS-284/64
PDB-219	Spindle Drive Belt VSS-286

Lubrication

VSS:	
Part Number	Description
SML-130	VSS-84/64 Spindle Gear Case
SML-150	VSS-84/64/86 Indexer Oil
SML-160	Column Ball Nut

VSS Series 2:

Part Number	Description
90056	Column Grease
SML-150	Indexer Oil

Column Drive Shear Pin

VSS-4273 (VSS machines only)

TECHNICAL DATA